

MUTE TANK PUMP

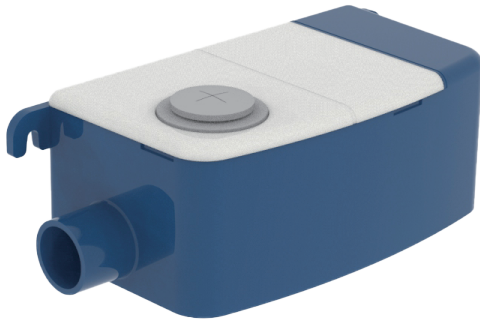

Thank you for purchasing this Mute Tank pump-40. This manual gives instructions on the correct installation. It is important that you follow these instructions carefully.

In the box

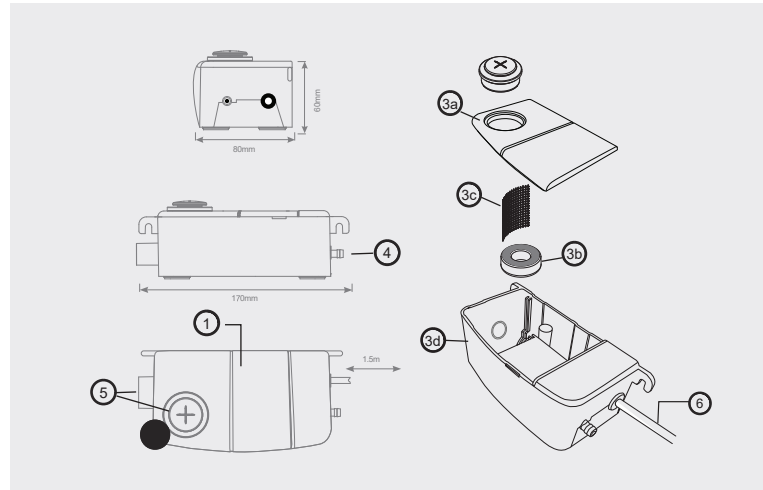

- ① Assembled mute tank
- ② 6mm i/d vinyl tube
- ③ Assembled Inline reservoir, including:
 - ③a lid & sensor cable
 - ③b float
 - ③c filter
 - ③d reservoir
- ④ 1.5m length of 6mm i/d vinyl tube
- ⑤ Inlet tube
- ⑥ Power cable

***NOTE:**

You will need several metres of 9mm o/d x 6mm i/d vinyl tube.

Technical Data

- Power supply: 100-240V AC 50/60Hz
- Discharge tube: 6mmID
- Max. flow: 40L/h (10.6GPH) @ 0 head
- Class: II appliance
- Sound level: 19 dB(A) @1M (3.3ft)
- Rated: Non continuous
- Max. discharge head: 20M (65.6ft)
- IP Protection: IPX7
- Max. unit output: 46kw / 157,000Btu/h
- Fully potted: Yes
- Safety switch: 3A Normally closed
- L×W×H: 180mm x 81mm x 70mm
- Max. water temperature: 70°C

Product Safety

Operation of this pump is determined by the position of the internal float relative to one of three sensors:

Low (motor off), Mid (motor on), High (hi level safety switch on). The hi level safety switch can be used to stop the air conditioning system in the unlikely event of pump failure.

IMPORTANT This pump has been designed for the removal of PH neutral condensate water only. It should not be used in swimming pools, marine environments, or environments that are particularly dusty or oily. This pump must not be run dry.

WARNING: This appliance is not intended for use by persons (including children) with reduced physical, sensory or mental capabilities, or lack of experience and knowledge, unless they have been given supervision or instruction concerning use of the appliance by a person responsible for their safety.

Children should be supervised to ensure that they do not play with the appliance.

Installation

1. FLOOR MOUNT / PIED DE SUPPORT

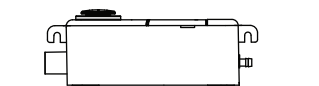

2. PLACE IN DRIP TRAY SUPPORT

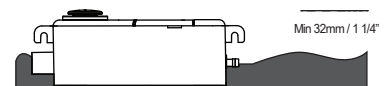

Typical Performance

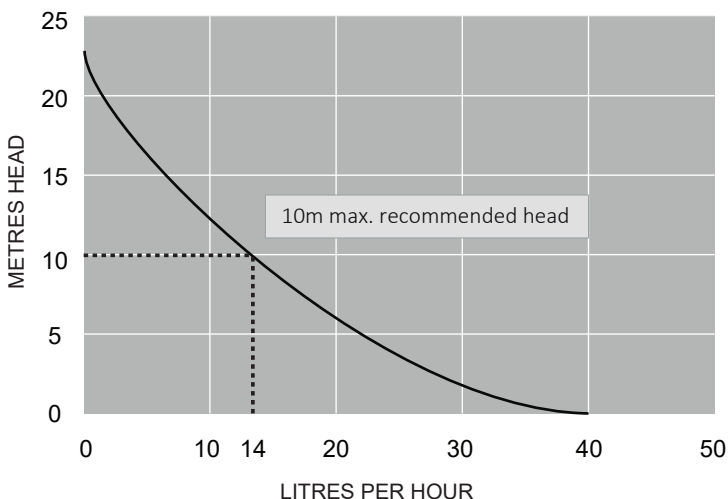

3. WALL MOUNTED

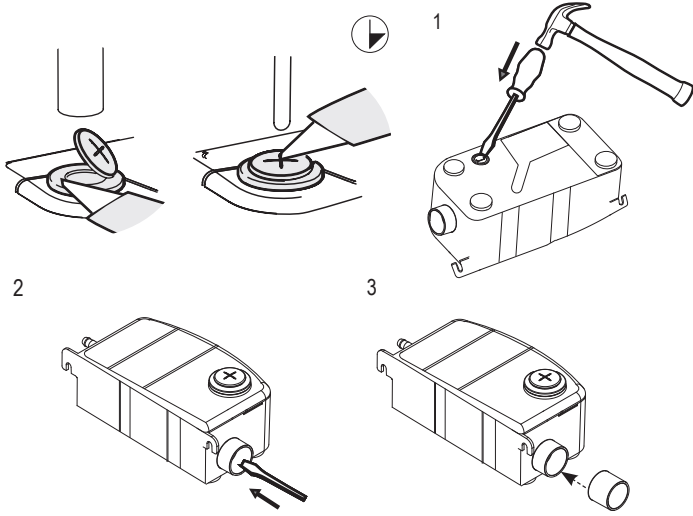
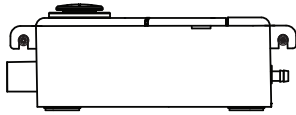

The Mute Tank can be installed in 1 of 3 ways:

- 1) Sitting level on a horizontal surface.
- 2) Sitting level in a drain pan
- 3) Fixed to a vertical surface using the integral hooks and the screws and rawl plugs supplied.

The Mute Tank Pump outlet can be connected to a 6mm / 1/4" or 10mm / 3/8" ID discharge pipe which must be secured using the cable ties provided. It is important to ensure that there are no kinks or restrictions in the discharge pipe.

The Mute Tank has four Condensate Inlets:

- 1) an opening is provided the top of the pump. The inlet pipe must be fitted so that it pushes fully through the yellow inlet bung into the opening and cannot come loose. The top of the inlet bung should be cut off for inlet pipe diameters >20mm / 3/4". For pipe diameters <20mm / 3/4" the yellow inlet bung should be pierced.
- 2) A 'knock out' on the bottom face can be removed for 'in pan' applications, note: 1/4 of the inlet bung must be removed to allow for ventilation.
- 3) 'outs' are provided in the side and rear of the Mute Tank pump.

Servicing

The pump should be flushed through with anti-bacterial wash every 6 months to avoid sludge build up in the pump reservoir. Note: Contractors should satisfy themselves that any chemicals used are suitable and will not damage the pump.

The pump lid, inlet bung, filter and float can be removed with ease for cleaning purposes (care should be taken as there may be water in the reservoir). IMPORTANT:

Ensure when the float is replaced that the magnet is face up. If the Supply Cord is damaged the pump must be switched off to avoid a hazard. The unit is potted so the cable cannot be replaced. The whole pump will need to be replaced.

Note: Servicing and maintenance should be carried out by a competent person. For further help please contact Aspen Pumps.

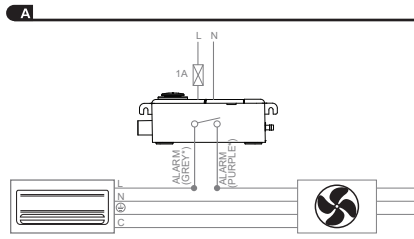
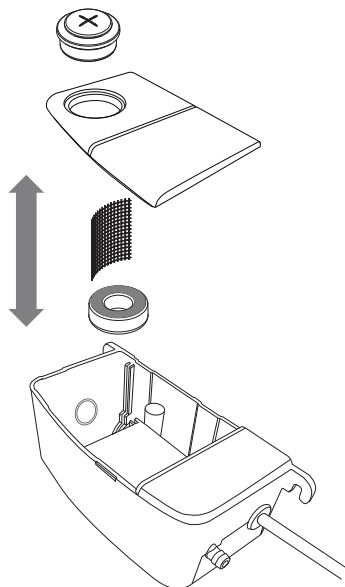

POWER

European 230V:

(L) LIVE: Brown
(N) NEUTRAL: Blue

US 230V:

(L) LINE 1: Black
(N) LINE 2: Red

US 115V:

(L) LINE 1: Black
(N) LINE 2: White

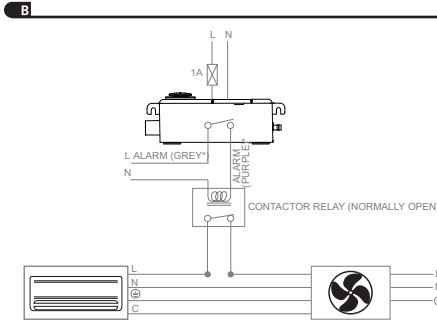

ALARM/VOLT FREE

European 230V:

Black
Black

US 230V / US 115V:

(N.C.) NORMALLY CLOSED: Purple
(COM) COMMON: Grey

* grey, purple

A. Live connection is < 3 amps

B. Via a suitable contactor relay (normally open) where the live connection is above 3 amps

C. Where interruption of the live or neutral connections lead to comms problems

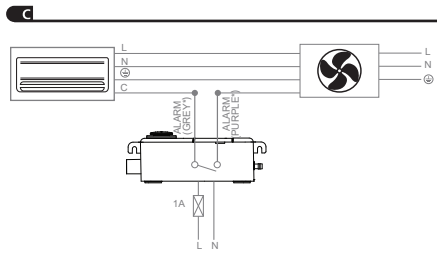

This pump must be installed by a competent person in accordance with these instructions. Following installation and commissioning, the operation of this pump should be explained to the user and these instructions left with them for future reference.

This pump must be connected to the correct power supply by a qualified electrician.

A 1 Amp fuse must be installed in the line supply to the pump.

The high level safety switch can be used to turn off the air conditioning in the unlikely event of pump failure. The switch uses a maximum rate of 3 Amps.

The following diagrams indicate three methods in which the hi level safety switch can be used. Following installation of the pump the reservoir should be filled with water until the motor runs. Pipes and connections should be checked for leaks and discharge of water checked; The operation of the safety switch should also be checked.

Trouble shooting

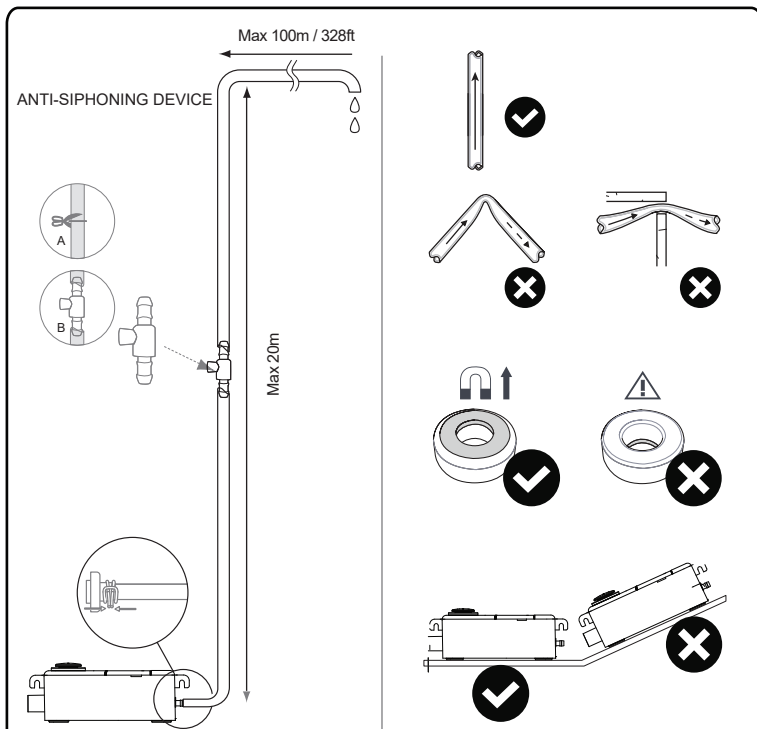

Fault Conditions:

In the unlikely event of a pump failure check the following:

Power Supply – Ensure power is supplied to pump.

Magnet – Check the float & magnet is the right way up (see diagram right)

Hi Level Safety Switch – Ensure hi level safety switch has not operated. If it has, check pump performance is suited to incoming flow rate.

Inlet Pipe – Check pipe is not blocked with debris or kinked.

Outlet Pipe – Check pipe, and outlet barb, is not blocked with debris or kinked.

Reservoir – Check reservoir is not blocked with debris.

Note: Fault conditions should be checked by a competent person.

If these checks do not resolve the problem please contact pumps for further assistance.