



A/C ACCESSORIES CATALOG



ADDRESS

No.499 Hongcan Road, Hongken Xiaoshan District, Hangzhou, China



TELEPHONE

Whatsapp: +1 8476443286



WEBSITES

Website: www.refcenter.us

Refcenter[®]



CONTENTS

01 PUMP SELECTOR	01
02 CONDENSATE PUMPS	
● Tranquil Series	03
● Mute Series	09
● Box Series	17
● PC Series	25
● Tank Series	27
03 CONDENSATE MANAGEMENT	
Condensate Switches / Traps	31
Drain Tubings	37
04 EQUIPMENT MOUNTING	
Wall Brackets	40
Mounting Stands, Blocks, and Feet	44
Anti Vibration Accessories	49
05 OTHER ACCESSORIES	
Tapes	52
Pre-installation Box	54
Line Set Cover & Fittings	56
Air Conditioning Installation Parts	59
06 INSTALLATION & MAINTENANCE TOOLS	
Vaccuum Pump	62
Recovery Machine	63
07 ABOUT US	65

Pump Selector

		System Type							Performance Data							Installation Method						
		Cassette	Ductless Mini Split	Ducted Unit	Cooler/Freezer	Humidifier	Dehumidifier	Boiler	Max Flow (L/H)	Max Head Lift (m)	Suction Lift (m)	Power(V)	Frequency(Hz)	Sound level @ 1m (dB)	Max. kW/Btu	Safety Shut-off	Inside Unit	Inside Trunking	Remotely	Below Unit		
Tranquil	Tranquil - S	•	•			•	•	•	40	20	2	100-240	50-60	<16-18	46/157000	Yes		✓				
	Tranquil - I		•						18	12				<17-19	16/54600				✓			
	Tranquil - C		•								/			<17-19								
	Tranquil - X		•					•	40	20				<16	46/157000						✓	
	Tranquil - D	•	•			•	•							<19					✓			
	Tranquil - T	•	•	•	•	•	•	•	110 GPH	24 ft				<30	/						✓	
Mute	Mute Box-40	•	•			•	•	•	40	20	2	100-240	50-60	<20	46/157000	Yes		✓				
	Mute Box-20	•	•			•	•	•	20					<18	28/95550							
	Mute Slim		•						15	12	<19											
	Mute Corner-40		•						40	20	/			<20	46/157000				✓			
	Mute Corner-20		•					20	<18					28/95550								
	Mute Wedge-40		•					•	40					<20	46/157000							✓
	Mute Wedge-20		•					•	20					<18	28/95550							
	Mute Tank	•	•	•	•	•	•	•	40					<19	46/157000							✓
Slim Box		•						15	12			2	115/230	50/60	<21	16/54600	Yes					
Easy Box		•													No		✓					
Box	Mini Box		•						10	15	/	100-240	50-60	<20	46/157000	Yes						
	Maxi Box	•	•			•	•	•	40	<18				28/95550							✓	
	Heart Box-40		•					•	20	20	<18			28/95550								
	Heart Box-20		•					•	20	20	<20			46/157000								
	MPC-40		•	•				•	40	20	<18			28/95550						✓		
	MPC-20		•	•				•	20	20												
Tank	Tank-V	•	•	•	•	•	•	•	250-580 (65-150GPH)	4.6-7.3 (15ft - 24ft)	/	115/230	50/60	35-45	/	Yes				✓		
	Tank-L	•	•	•	•	•	•	•						450 (119GPH)			6.1 20ft	<35				
	Tank-X	•	•	•	•	•	•	•														
PC	PC-DC	•							70	1.2		12Vdc	/	<35		Yes/No	✓					
	PC-AC40	•							40	0.95		115/230	50/60	<30	/							
	PC-AC70	•							70	1.2			50/60	<35								

Tranquil-I



CONDENSATE PUMP

- Capacitive sensor
- Variable flow rate
- Diagnostic LED
- Slim design for easy installation
- Built-in operation tracking
- Ultra-quiet operation
- Up to 16 kw/54,600 Btu/h

- Max. flow 18 L/h (4.8GPH)
- Sound level < 17-19 dB(A) @ 1M (3.3ft)
- Max. discharge head 12 M (39.4ft)

The Tranquil-I features a capacitive sensor for water detection, enhancing reliability over traditional float switches. Its soft-start mode minimizes startup noise and extends the lifespan of the pump and electronic components. A built-in counter tracks operating time and provides alarm notifications for optimal maintenance.

> TECHNICAL DATA < TYPICAL PERFORMANCE <

- Power supply: 100-240V AC 50/60Hz <4W
- Max. flow: 18L/h (4.8GPH) , range from 12-18L/H (3.2-4.8GPH)
- Sound level: 17-19dB(A)@1M (3.3ft)
- Max. discharge head: 12 M (39.4ft)
- Max. suction lift: 2 M (6.6ft)
- Max. unit output: 16 kw / 54,600 Btu/h
- Safety switch: 3A Normally closed
- Max. water temperature: 40 C
- Discharge tube: 6mmID
- Class: II appliance
- Protection: Fully potted, IP-45
- LxWxH: 187mm x 29mm x 29mm

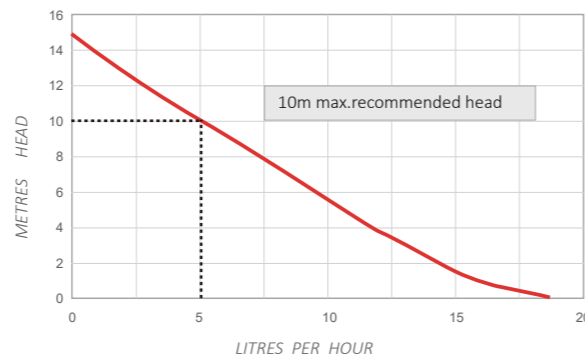

> IN THE BOX < DIMENSION <

- 1 Assembled Tranquil - I
- 2 Assembled inline resevoir
- 3 Plug connector
- 4 150cm length of 6mm I/D vinyl tube
- 5 Silicone tube 15cm
- 6 Power cable
- 7 1A fuse
- 8 Anti-siphon valve
- 9 Check valve
- 10 3M tape 2x50mmx20mmx1mm
- 11 3M tape 1x50mmx20mmx2.5mm
- 12 Nylon clamps 4x200mmx4mm

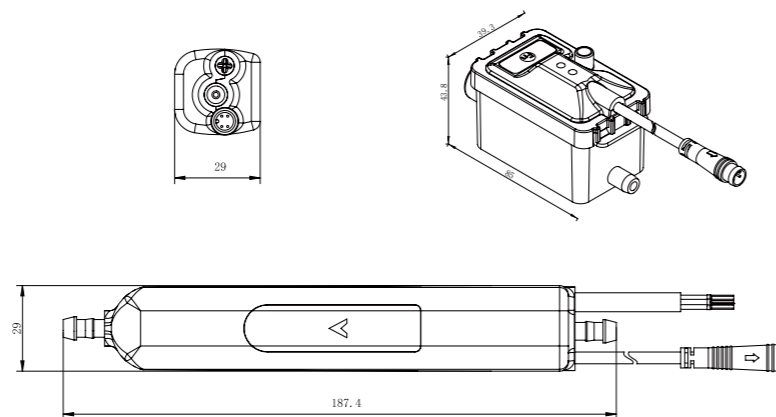

Tranquil-S



CONDENSATE PUMP

- Capacitive sensor
- Variable flow rate
- Diagnostic LED
- Powerful performance
- Built-in operation tracking
- Ultra-quiet operation
- Up to 46 kw / 157,000 Btu/h

- Max. flow 40 L/h (10.6GPH)
- Sound level < 16-18 dB(A) @ 1M (3.3ft)
- Max. discharge head 20 M (65.6ft)

The Tranquil-S features a capacitive sensor for water detection, enhancing reliability over traditional float switches. Its soft-start mode minimizes startup noise and extends the lifespan of the pump and electronic components. A built-in counter tracks operating time and provides alarm notifications for optimal maintenance.

> TECHNICAL DATA < TYPICAL PERFORMANCE <

- Power supply: 100-240V AC 50/60Hz <4W
- Max. flow: 40 L/H (10.6GPH), range from 20-40L/H (5.3-10.6GPH)
- Sound level: 16-18dB(A)@1M (3.3ft)
- Max. discharge head: 20 M (65.6ft)
- Max. suction lift: 2 M (6.6ft)
- Max. unit output: 46 kw / 157,000 Btu/h
- Safety switch: 3A Normally closed
- Max. water temperature: 40 C
- Discharge tube: 6mmID
- Class: II appliance
- Protection: Fully potted, IP-45
- LxWxH: 185mm x 36mm x 34mm

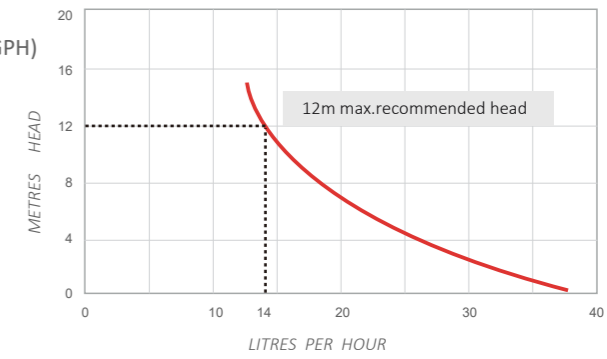

> IN THE BOX < DIMENSION <

- 1 Assembled Tranquil-S
- 2 Assembled inline resevoir
- 3 Plug connerector
- 4 150cm length of 6mm I/D vinyl tube
- 5 Silicone tube 15cm
- 6 Power cable
- 7 1A fuse
- 8 Anti-siphon valve
- 9 Check valve
- 10 3M tape 2x50mmx20mmx1mm
- 11 3M tape 1x50mmx20mmx2.5mm
- 12 Nylon clamps 4x200mmx4mm

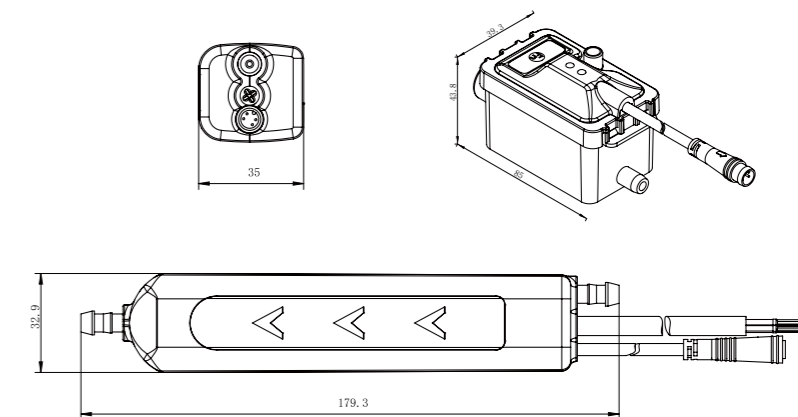

Tranquil-X



CONDENSATE PUMP

- Capacitive sensor
- Variable flow rate
- Diagnostic LED
- Quick and simple installation
- Built-in operation tracking
- Ultra-quiet operation
- Up to 46 kw / 157,000 Btu/h

- Max. flow 40 L/h (10.6GPH)
- Sound level < 16 dB(A) @ 1M (3.3ft)
- Max. discharge head 20 M (65.6ft)

The Tranquil-x features a capacitive sensor for water detection, enhancing reliability over traditional float switches. Its soft-start mode minimizes startup noise and extends the lifespan of the pump and electronic components. A built-in counter tracks operating time and provides alarm notifications for optimal maintenance.

> TECHNICAL DATA < TYPICAL PERFORMANCE <

- Power supply: 100-240V AC 50/60Hz <4W
- Max. flow: 40L/h (10.6GPH), range from 20-40L/H (5.3-10.6GPH)
- Sound level: 16dB(A)@1M (3.3ft)
- Max. discharge head: 20 M (65.6ft)
- Max. suction lift: 2 M (6.6ft)
- Max. unit output: 46 kw / 157,000 Btu/h
- Safety switch: 3A Normally closed
- Max. water temperature: 40 C
- Discharge tube: 6mmID
- Class: II appliance
- Protection: Fully potted, IP-45
- LxWxH: 281mm x 55mm x 69mm

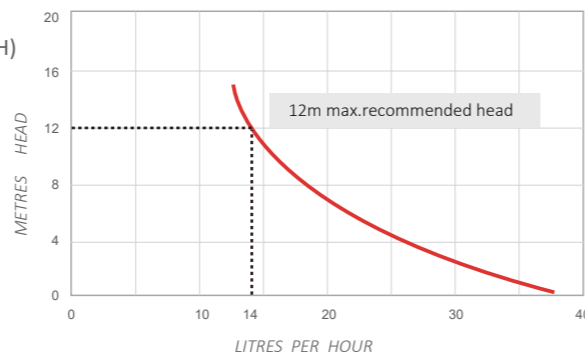

> IN THE BOX < DIMENSION <

- 1A fuse x 1
- Installation screw x 2
- Expansion plug x 2
- Level gauge x 1
- Connection clamp x 1
- Nylon clamps 200mmx4mm x 2
- Drilling schematic template x 1
- Anti-siphon valve x 1

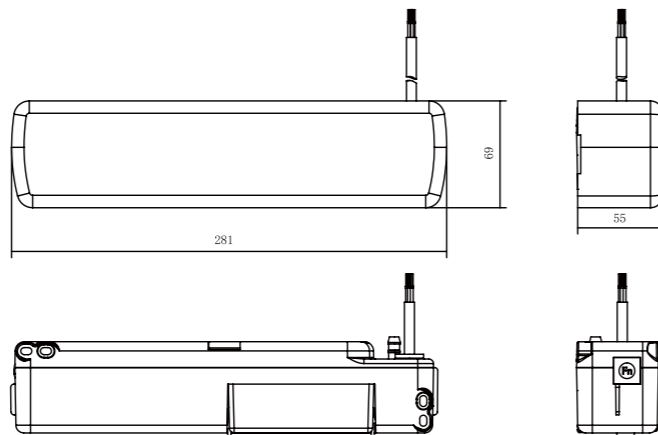

Tranquil-D



CONDENSATE PUMP

- Capacitive sensor
- Variable flow rate
- Diagnostic LED
- Submersible in Condensate Pans
- Built-in operation tracking
- Ultra-quiet operation
- Up to 46 kw / 157,000 Btu/h

- Max. flow 40 L/h (10.6GPH)
- Sound level < 19 dB(A) @ 1M (3.3ft)
- Max. discharge head 20 M (65.6ft)

The Tranquil-D features a capacitive sensor for water detection, enhancing reliability over traditional float switches. Its soft-start mode minimizes startup noise and extends the lifespan of the pump and electronic components. Completely-sealed design with IP68 protection grade makes Tranquil-D submersible in condensate trays/pans, with high pumping capacity.

> TECHNICAL DATA < TYPICAL PERFORMANCE <

- Power supply: 100-240V AC 50/60Hz <4W
- Max. flow: 40L/h (10.6GPH), range from 20-40L/H (5.3-10.6GPH)
- Sound level: 19dB(A)@1M (3.3ft)
- Max. discharge head: 20 M (65.6ft)
- Max. suction lift: 2 M (6.6ft)
- Max. unit output: 46 kw / 157,000 Btu/h
- Safety switch: 3A Normally closed
- Max. water temperature: 40 C
- Discharge tube: 6mmID
- Class: II appliance
- Protection: IP68
- LxWxH: 176mm x 34mm x 41mm

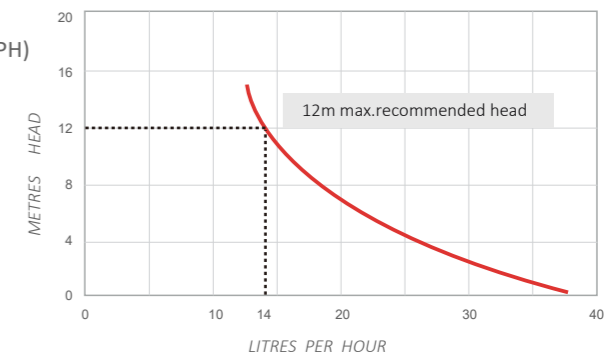

> IN THE BOX < DIMENSION <

- Assembled Tranquil - D
- 150cm length of 6mm I/D vinyl tube
- Power cable
- 1A fuse
- Anti-siphon valve
- Check valve
- Nylon clamps 4x200mmx4mm

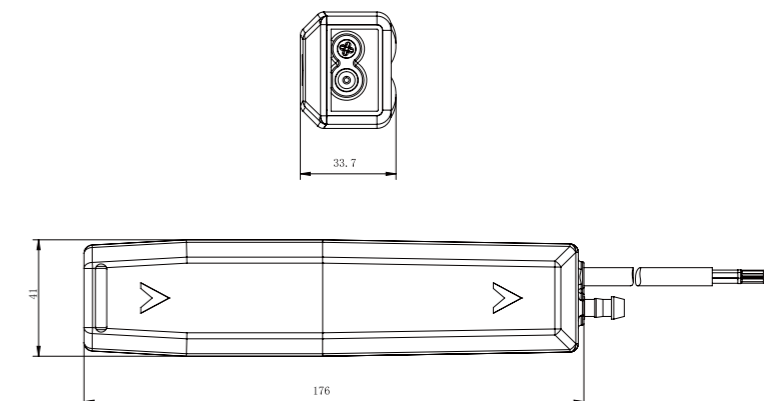

Tranquil-C

CONDENSATE PUMP

- Capacitive sensor
- Variable flow rate
- Diagnostic LED
- Reset function
- Built-in operation tracking
- Installed in trunking elbow
- Up to 16 kw/54,600 Btu/h



- Max. flow 18 L/h (4.8GPH)
- Sound level < 17-19 dB(A) @ 1M (3.3ft)
- Max. discharge head 12M (39.4ft)

The Tranquil-C uses a capacitive sensor for water detection, enhancing reliability over traditional float switches. Its soft-start mode minimizes startup noise and extends the lifespan of the pump and electronic components. A built-in counter tracks operating time and provides alarm notifications for optimal maintenance.

> TECHNICAL DATA < TYPICAL PERFORMANCE <

- Power supply: 100-240V AC 50/60Hz <4W
- Max. flow: 18 L/H (4.8GPH), range from 12-18L/H (3.2-4.8GPH)
- Sound level: 17-19dB(A)@1M (3.3ft)
- Max. discharge head: 12M (39.4ft)
- Max. suction lift: 2M (6.6ft)
- Max. unit output: 16kw / 54,600 Btu/h
- Safety switch: 3A Normally closed
- Max. water temperature: 40 °C
- Discharge tube: 6mmID
- Class: II appliance
- Protection: Fully potted, IP-45
- LxWxH: 82.6mm x 47.8mm x 96.9mm

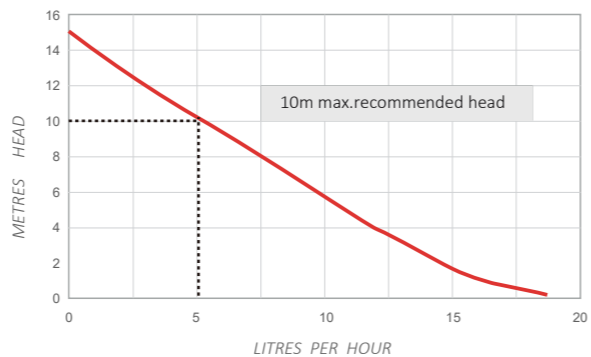

> IN THE BOX < DIMENSION <

- 1 Assembled Tranquil-C
- 2 breather hole 6mm od
- 3 Assembled Inline reservoir
- 4 1.5m length of 6mm i/d vinyl tube
- 5 Inlet tube
- 6 Power Cable
- 7 Anti-siphon valve
- 8 4 x 200mm x 4mm cable ties
- 9 Check valve
- 10 1 A fuse
- 11 Line Set (As option)

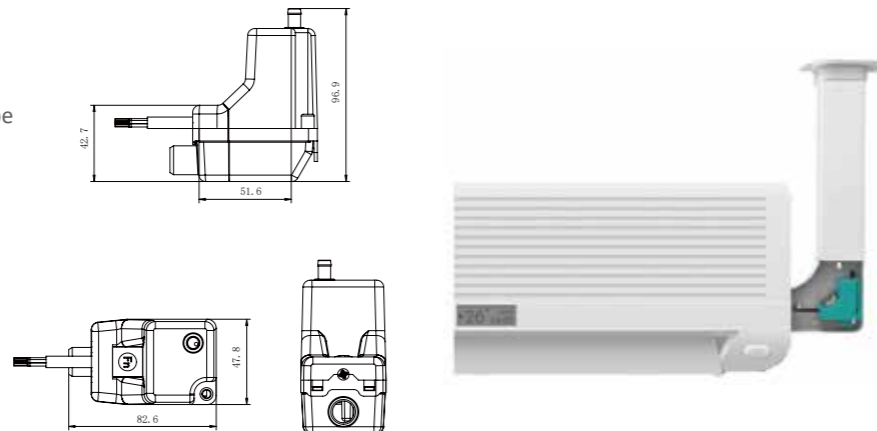

Tranquil-T

CONDENSATE PUMP

- Automatic Optical-level Sensor Switch
- 0.46 Gallon Rustproof, High Impact ABS Tank
- Discharge tube compatible with both 3/8" & 1/4"
- Optional dual alarm system for enhanced safety and reliability.
- 6-feet power cord
- 4 inlets 1.1"



- Max. flow 587 L/h (155GPH)
- Sound level < 30 dB(A) @ 1M (3.3ft)
- Max. discharge head 7.2M (24ft)

POWER PLUG OPTIONS:

- No plug
- Single plug (customer-specified)
- Dual plugs (115 V / 230 V)

> TYPICAL PERFORMANCE <

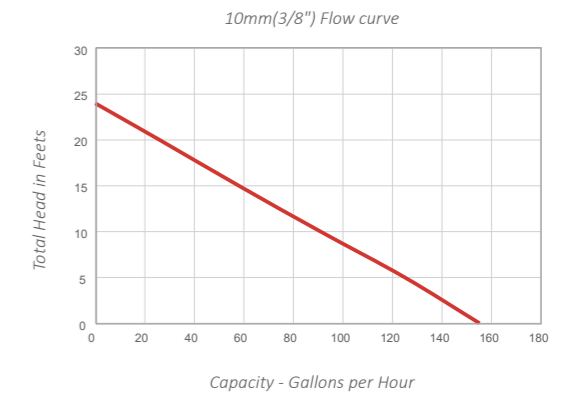
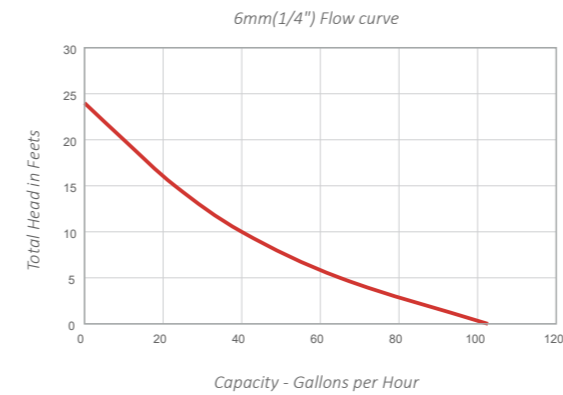

> TECHNICAL DATA < DIMENSION <

- Power supply: 100-240V AC 50/60Hz 40W
- Max. flow: 587 L/h (155GPH)
- Sound level: 30dB(A)@1M (3.3ft)
- Max. discharge head: 7.2M (24ft)
- Max. water temperature: 60 °C
- Discharge tube: 10mm ID(1/4")/6mm ID(3/8")
- Class: II appliance
- IP Protection: IP24

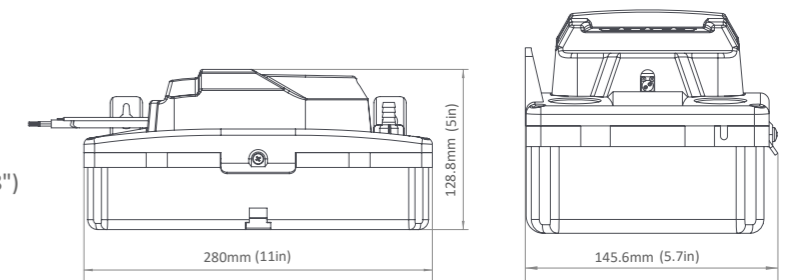

MUTE WEDGE-20



CONDENSATE PUMP

- Float Switch Detection
- Simple and quick to install
- Anti-vibration
- Silent Operation

- Max. flow 20L/h (5.3GPH) @ 0 head
- Sound level < 18 dB(A) @ 1M (3.3ft)
- Max. discharge head 20M (65.6ft)

The sleek, compact design of the Mute series pumps makes them ideal for integration with mini-split and ducted HVAC systems. Operating via float switch mechanism, Mute series delivers exceptional condensate removal performance while maintaining whisper-quiet operation, ensuring optimal environmental comfort.

> TECHNICAL DATA < TYPICAL PERFORMANCE <

- Power supply: 100-240V AC 50/60Hz
- Max. flow: 20L/h (5.3GPH) @ 0 head
- Sound level: 18 dB(A) @1M (3.3ft)
- Max. discharge head: 20M (65.6ft)
- Water Storage: 230ml
- Max. unit output: 28kw / 95,550Btu/h
- Safety switch: 3A Normally closed
- Max. water temperature: 70°C
- Discharge tube: 6mmID
- Class: II appliance
- Rated: Continuous
- IP Protection: IPX5
- Fully potted: Yes
- LxWxH: 164mm x 70mm x 106mm

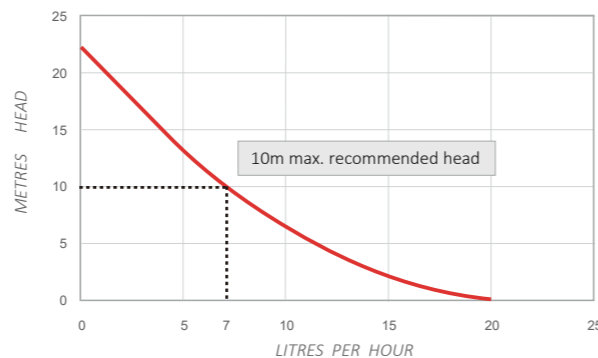

> DIMENSION

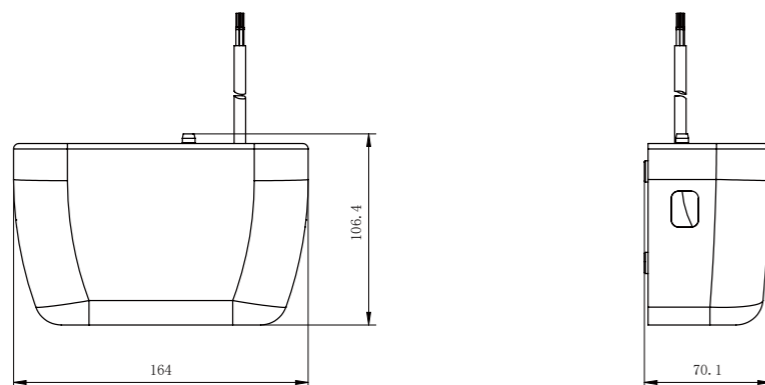

MUTE WEDGE-40



CONDENSATE PUMP

- Float Switch Detection
- High performance
- Simple and quick to install
- Anti-vibration
- Silent Operation

- Max. flow 40L/h (10.6GPH) @ 0 head
- Sound level < 20 dB(A) @ 1M (3.3ft)
- Max. discharge head 20M (65.6ft)

The sleek, compact design of the Mute series pumps makes them ideal for integration with mini-split and ducted HVAC systems. Operating via float switch mechanism, Mute series delivers exceptional condensate removal performance while maintaining whisper-quiet operation, ensuring optimal environmental comfort.

> TECHNICAL DATA < TYPICAL PERFORMANCE <

- Power supply: 100-240V AC 50/60Hz
- Max. flow: 40L/h (10.6GPH) @ 0 head
- Sound level: 20dB(A) @1M (3.3ft)
- Max. discharge head: 20M (65.6ft)
- Water Storage: 230ml
- Max. unit output: 46kw / 157,000Btu/h
- Safety switch: 3A Normally closed
- Max. water temperature: 70°C
- Discharge tube: 6mmID
- Class: II appliance
- Rated: Continuous
- IP Protection: IPX5
- Fully potted: Yes
- LxWxH: 164mm x 70mm x 106mm

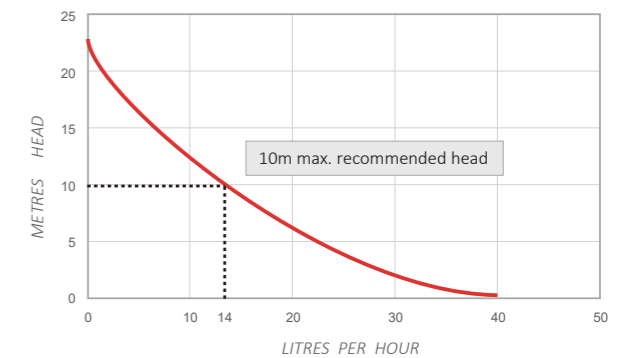

> DIMENSION

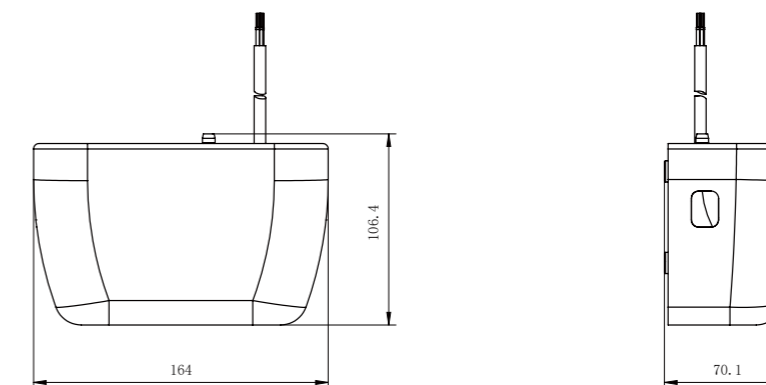

MUTE BOX-20



CONDENSATE PUMP

- Float Switch Detection
- Anti-vibration
- Plug & Play
- Silent Operation

- Max. flow 20L/h (5.3GPH) @ 0 head
- Sound level < 18 dB(A) @ 1M (3.3ft)
- Max. discharge head 20M (65.6ft)

The sleek, compact design of the Mute series pumps makes them ideal for integration with mini-split and ducted HVAC systems. Operating via float switch mechanism, Mute series delivers exceptional condensate removal performance while maintaining whisper-quiet operation, ensuring optimal environmental comfort.

> TECHNICAL DATA

- Power supply: 100-240V AC 50/60Hz
- Max. flow: 20L/h (5.3GPH) @ 0 head
- Sound level: 18 dB(A) @1M (3.3ft)
- Max. discharge head: 20M (65.6ft)
- Max. suction lift: 2M (6.6ft)
- Max. unit output: 28kw / 95,550Btu/h
- Safety switch: 3A Normally closed
- Max. water temperature: 70°C
- Discharge tube: 6mmID
- Class: II appliance
- Rated: Continuous
- IP Protection: IPX5
- Fully potted: Yes
- LxWxH: 185mm x 36mm x 34mm

TYPICAL PERFORMANCE <

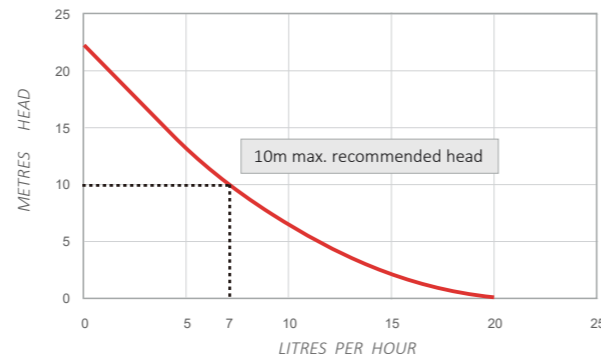

> IN THE BOX

- 1 Assembled MUTE BOX
- 2 6mm i/d vinyl tube
- 3 Assembled Inline reservoir
- 4 1.5m length of 6mm i/d vinyl tube
- 5 Inlet tube
- 6 Self adhesive velcro strips x 2
- 7 Anti-siphon valve
- 8 Check valve
- 9 Power cable
- 10 4 x 200mm x 4mm cable ties

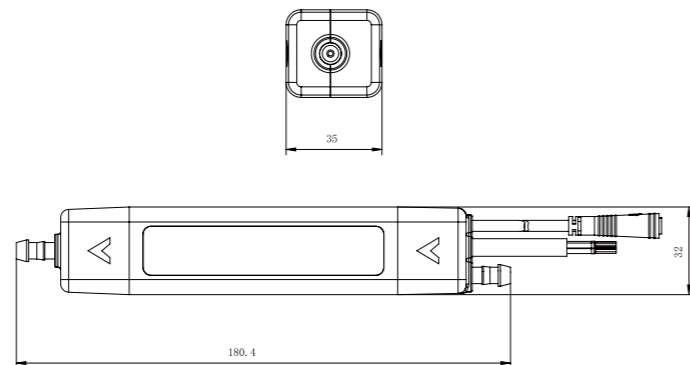

DIMENSION <

MUTE BOX-40



CONDENSATE PUMP

- Float Switch Detection
- Anti-vibration
- Plug & Play
- Silent Operation
- High performance

- Max. flow 40L/h (10.6GPH) @ 0 head
- Sound level < 20 dB(A) @ 1M (3.3ft)
- Max. discharge head 20M (65.6ft)

The sleek, compact design of the Mute series pumps makes them ideal for integration with mini-split and ducted HVAC systems. Operating via float switch mechanism, Mute series delivers exceptional condensate removal performance while maintaining whisper-quiet operation, ensuring optimal environmental comfort.

> TECHNICAL DATA

- Power supply: 100-240V AC 50/60Hz
- Max. flow: 40L/h (10.6GPH) @ 0 head
- Sound level: 20 dB(A) @1M (3.3ft)
- Max. discharge head: 20M (65.6ft)
- Max. suction lift: 2M (6.6ft)
- Max. unit output: 46kw / 157,000Btu/h
- Safety switch: 3A Normally closed
- Max. water temperature: 70°C
- Discharge tube: 6mmID
- Class: II appliance
- Rated: Continuous
- IP Protection: IPX5
- Fully potted: Yes
- LxWxH: 185mm x 36mm x 34mm

TYPICAL PERFORMANCE <

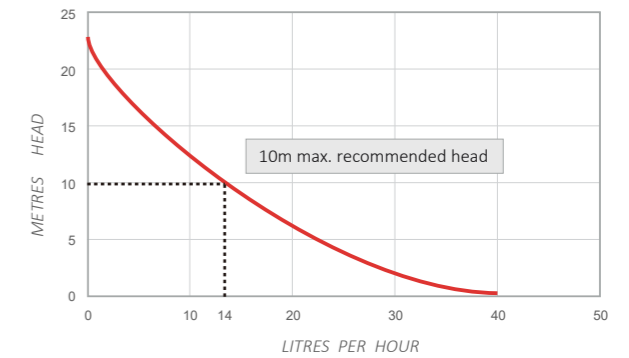

> IN THE BOX

- 1 Assembled MUTE BOX
- 2 6mm i/d vinyl tube
- 3 Assembled Inline reservoir
- 4 1.5m length of 6mm i/d vinyl tube
- 5 Inlet tube
- 6 Self adhesive velcro strips x 2
- 7 Anti-siphon valve
- 8 Check valve
- 9 Power cable
- 10 4 x 200mm x 4mm cable ties

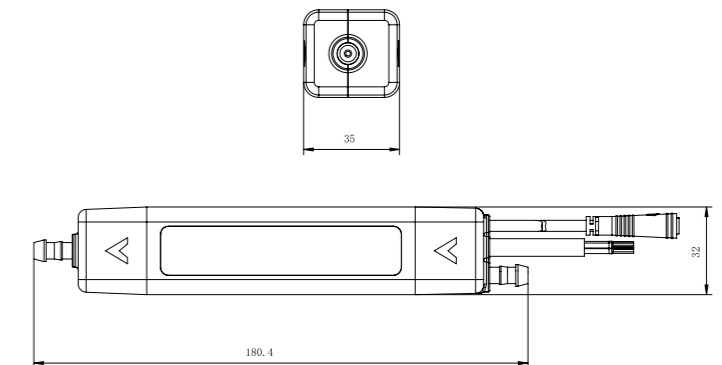

DIMENSION <

MUTE SLIM



CONDENSATE PUMP

- Float Switch Detection
- Silent Operation
- Slim design to fit various installation methods
- Anti-vibration
- Plug & Play
- Max. flow 15L/h (4.0GPH) @ 0 head
- Sound level < 19 dB(A) @ 1M (3.3ft)
- Max. discharge head 12M (39.4ft)

The sleek, compact design of the Mute series pumps makes them ideal for integration with mini-split and ducted HVAC systems. Operating via float switch mechanism, Mute series delivers exceptional condensate removal performance while maintaining whisper-quiet operation, ensuring optimal environmental comfort.

> TECHNICAL DATA < TYPICAL PERFORMANCE <

- Power supply: 100-240V AC 50/60Hz
- Max. flow: 15L/h (4.0GPH) @ 0 head
- Sound level: 19 dB(A) @1M (3.3ft)
- Max. discharge head: 12M (39.4ft)
- Max. unit output: 28kw / 95,550Btu/h
- Safety switch: 3A Normally closed
- Max. water temperature: 70°C
- Discharge tube: 6mmID
- Class: II appliance
- Rated: Continuous
- IP Protection: IPX5
- LxWxH: 187mm x 29mm x 27mm

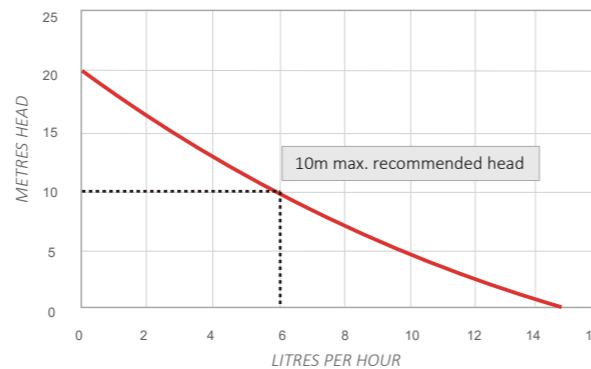

> IN THE BOX < DIMENSION <

- Assembled MUTE SLIM
- 6mm i/d vinyl tube
- Assembled Inline reservoir
- 1.5m length of 6mm i/d vinyl tube
- Inlet tube
- 2 x self adhesive velcro strips
- Check valve
- Anti-siphon valve
- Power cable
- 4 x 200mm x 4mm cable ties

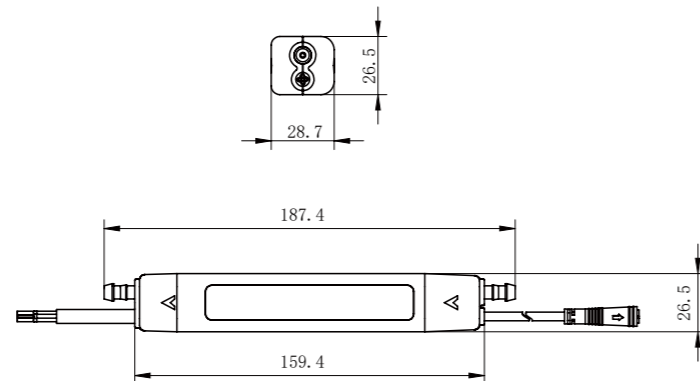

MUTE TANK



CONDENSATE PUMP

- Float Switch Detection
- High performance
- Fit various installation methods
- Anti-vibration
- Silent Operation
- Max. flow 40L/h (10.6GPH) @ 0 head
- Sound level < 19 dB(A) @ 1M (3.3ft)
- Max. discharge head 20M (65.6ft)

The sleek, compact design of the Mute series pumps makes them ideal for integration with mini-split and ducted HVAC systems. Operating via float switch mechanism, Mute series delivers exceptional condensate removal performance while maintaining whisper-quiet operation, ensuring optimal environmental comfort.

> TECHNICAL DATA < TYPICAL PERFORMANCE <

- Power supply: 100-240V AC 50/60Hz
- Max. flow: 40L/h (10.6GPH) @ 0 head
- Sound level: 19 dB(A) @1M (3.3ft)
- Max. discharge head: 20M (65.6ft)
- Max. unit output: 46kw / 157,000Btu/h
- Safety switch: 3A Normally closed
- Max. water temperature: 70°C
- Discharge tube: 6mmID
- Class: II appliance
- Rated: Continuous
- IP Protection: IPX7
- Fully potted: Yes
- LxWxH: 180mm x 81mm x 70mm

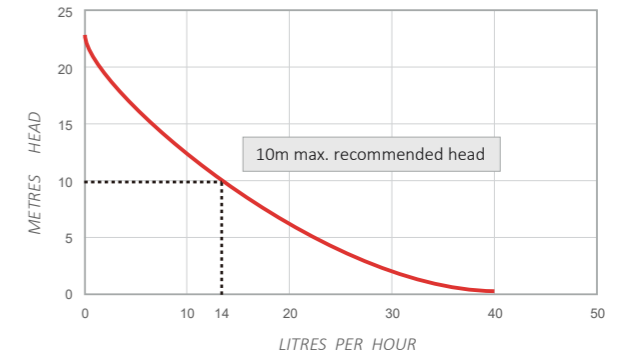

> IN THE BOX < DIMENSION <

- Assembled MUTE TANK
- 6mm i/d vinyl tube
- Assembled Inline reservoir
- 1.5m length of 6mm i/d vinyl tube
- Inlet tube
- Power cable

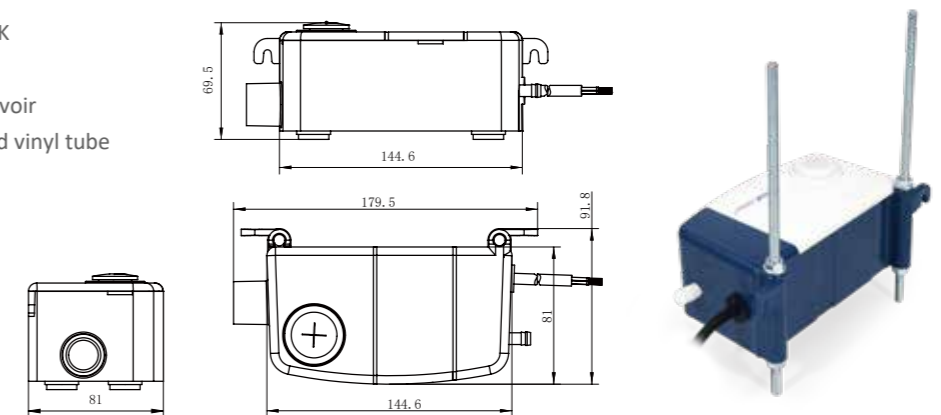

MUTE CORNER-20



CONDENSATE PUMP

- *Float Switch Detection*
- *Plug & Play*
- *Fit with trunking elbow*
- *Anti-vibration*
- *Silent Operation*
- Max. flow 20L/h (5.3GPH) @ 0 head
- Sound level < 18 dB(A) @ 1M (3.3ft)
- Max. discharge head 20M (65.6ft)

The sleek, compact design of the Mute series pumps makes them ideal for integration with mini-split and ducted HVAC systems. Operating via float switch mechanism, Mute series delivers exceptional condensate removal performance while maintaining whisper-quiet operation, ensuring optimal environmental comfort.

> TECHNICAL DATA < TYPICAL PERFORMANCE <

- Power supply: 100-240V AC 50/60Hz
- Max. flow: 20L/h (5.3GPH) @ 0 head
- Sound level: 18 dB(A) @1M (3.3ft)
- Max. discharge head: 20M (65.6ft)
- Max. unit output: 28kw / 95,550Btu/h
- Safety switch: 3A Normally closed
- Max. water temperature: 70°C
- Discharge tube: 6mmID
- Class: II appliance
- Rated: Continuous
- IP Protection: IPX5
- LxWxH: 96mm x 47mm x 94mm

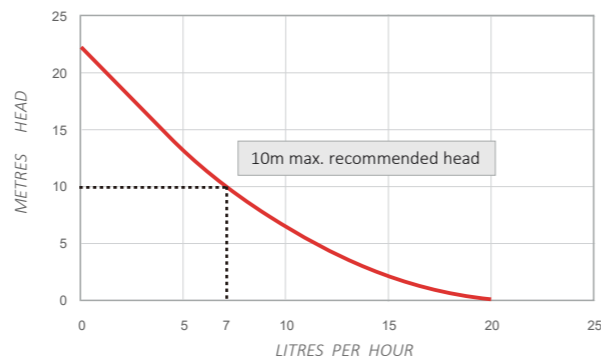

> IN THE BOX < DIMENSION <

- 1 Assembled MUTE CORNER
- 2 6mm i/d vinyl tube
- 3 Assembled Inline reservoir
- 4 1.5m length of 6mm i/d vinyl tube
- 5 Inlet tube
- 6 4 pin socket
- 7 Anti-siphon valve
- 8 Check valve
- 9 4 x 200mm x 4mm cable ties

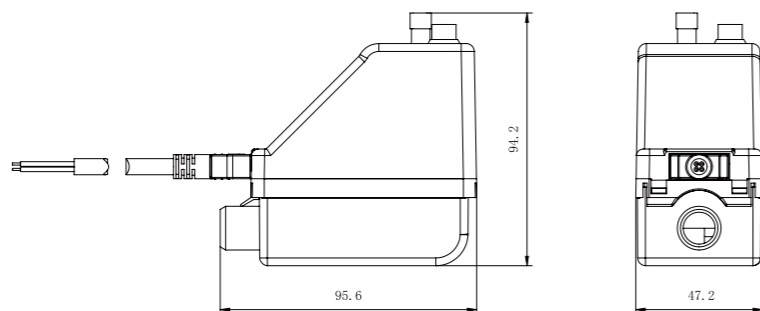

MUTE CORNER-40



CONDENSATE PUMP

- *Float Switch Detection*
- *Plug & Play*
- *Fit with trunking elbow*
- *Anti-vibration*
- *Silent Operation*
- Max. flow 40L/h (10.6GPH) @ 0 head
- Sound level < 20 dB(A) @ 1M (3.3ft)
- Max. discharge head 20M (65.6ft)

The sleek, compact design of the Mute series pumps makes them ideal for integration with mini-split and ducted HVAC systems. Operating via float switch mechanism, Mute series delivers exceptional condensate removal performance while maintaining whisper-quiet operation, ensuring optimal environmental comfort.

> TECHNICAL DATA < TYPICAL PERFORMANCE <

- Power supply: 100-240V AC 50/60Hz
- Max. flow: 40L/h (10.6GPH) @ 0 head
- Sound level: 20 dB(A) @1M (3.3ft)
- Max. discharge head: 20M (65.6ft)
- Max. unit output: 46kw / 157,000Btu/h
- Safety switch: 3A Normally closed
- Max. water temperature: 70°C
- Discharge tube: 6mmID
- Class: II appliance
- Rated: Continuous
- IP Protection: IPX5
- LxWxH: 96mm x 47mm x 94mm

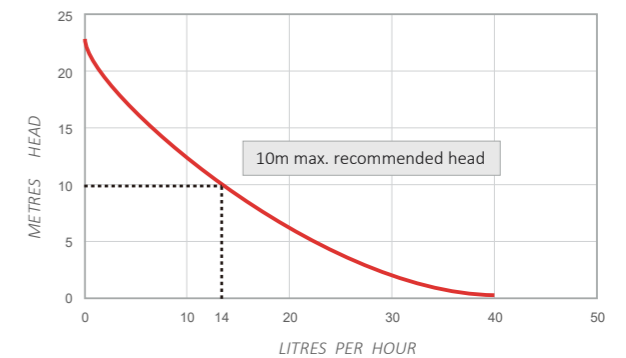

> IN THE BOX < DIMENSION <

- 1 Assembled MUTE CORNER
- 2 6mm i/d vinyl tube
- 3 Assembled Inline reservoir
- 4 1.5m length of 6mm i/d vinyl tube
- 5 Inlet tube
- 6 4 - pin socket
- 7 Anti-siphon valve
- 8 Check valve
- 9 4 x 200mm x 4mm cable ties



HEART BOX-20



CONDENSATE PUMP

- Plug & Play
- Anti-vibration
- Silent Operation
- Quick and simple installation

- Max. flow 20L/h (5.3GPH) @ 0 head
- Sound level < 18 dB(A) @ 1M (3.3ft)
- Max. discharge head 20M (65.6ft)

> TECHNICAL DATA

- Power supply: 100-240V AC 50/60Hz
- Max. flow: 20L/h(5.3GPH) @ 0 head
- Sound level: 18 dB(A) @1M (3.3ft)
- Max. discharge head: 20M (65.6ft)
- Tank capacity: 300ml
- Max. unit output: 28kw / 95,550Btu/h
- Safety switch: 3A Normally closed
- Max. water temperature: 70°C
- Discharge tube: 6mmID
- Class: II appliance
- Rated: Continuous
- Fully potted: Yes
- LxWxH: 171mm x 83.4mm x 171.5mm

TYPICAL PERFORMANCE <

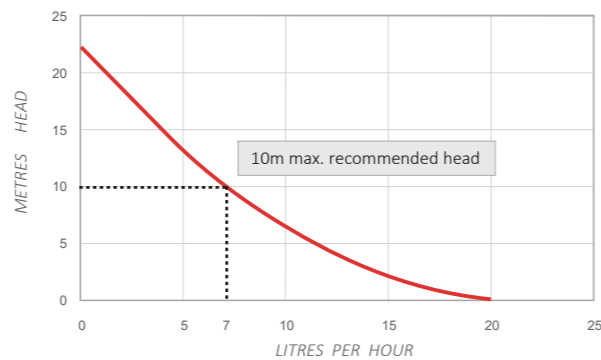

> IN THE BOX

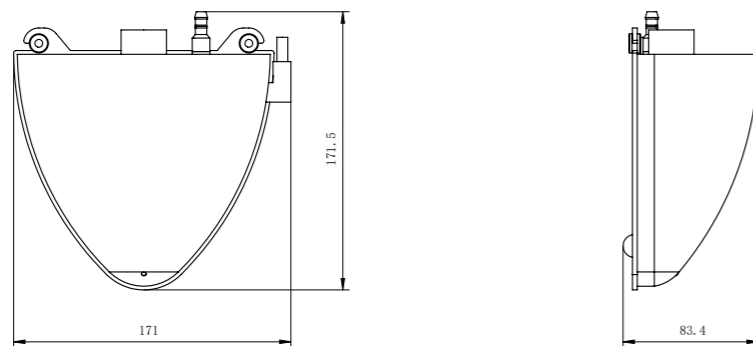

HEART BOX-40



CONDENSATE PUMP

- High Performance
- Plug & Play
- Anti-vibration
- Quiet Operation
- Quick and simple installation

- Max. flow 40L/h (10.6GPH) @ 0 head
- Sound level < 20 dB(A) @ 1M (3.3ft)
- Max. discharge head 20M (65.6ft)

> TECHNICAL DATA

- Power supply: 100-240V AC 50/60Hz
- Max. flow: 40L/h (10.6GPH) @ 0 head
- Sound level: 20 dB(A) @1M (3.3ft)
- Max. discharge head: 20M (65.6ft)
- Tank capacity: 300ml
- Max. unit output: 46kw / 157,000Btu/h
- Safety switch: 3A Normally closed
- Max. water temperature: 70°C
- Discharge tube: 6mmID
- Class: II appliance
- Rated: Continuous
- Fully potted: Yes
- LxWxH: 171mm x 83.4mm x 171.5mm

TYPICAL PERFORMANCE <

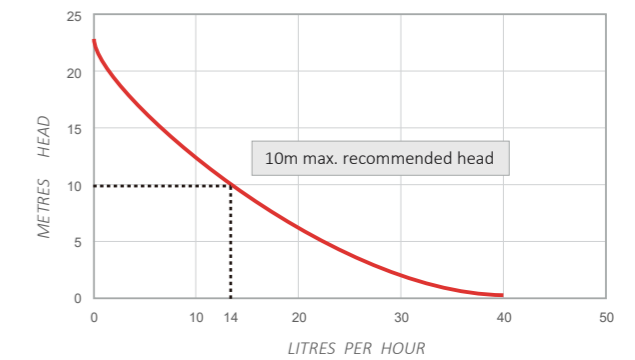

> IN THE BOX

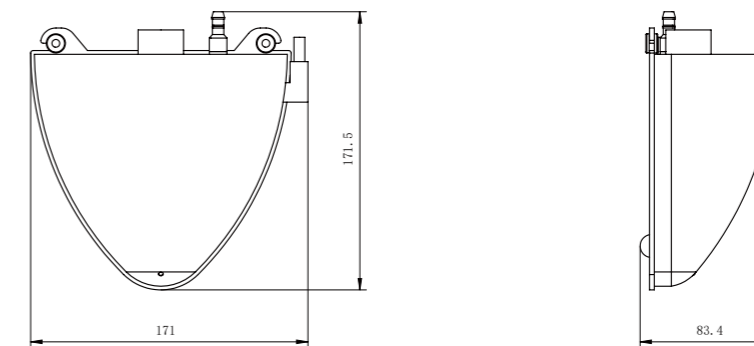

SLIM BOX



CONDENSATE PUMP

- Ultra slim design
- Plug & Play
- Anti-vibration
- Quiet Operation

- Max. flow 15L/h (4GPH) @ 0 head
- Sound level < 21 dB(A) @ 1M (3.3ft)
- Max. discharge head 12M (39.4ft)

> TECHNICAL DATA

- Power supply: 115V 50Hz or 230V 50/60Hz
- Max. flow: 15L/h (4GPH) @ 0 head
- Sound level: 21 dB(A) @ 1M (3.3ft)
- Max. discharge head: 12M (39.4ft)
- Max. suction lift: 2M (6.6ft)
- Max. unit output: 16kw / 54,600 Btu/h
- Safety switch: 3A Normally closed
- Max. water temperature: 40°C
- Discharge tube: 6mmID
- Class: II appliance
- Rated: Non continuous
- IP Protection: IPX5
- Thermal protection: Yes
- LxWxH: 148mm x 29mm x 29mm

TYPICAL PERFORMANCE <

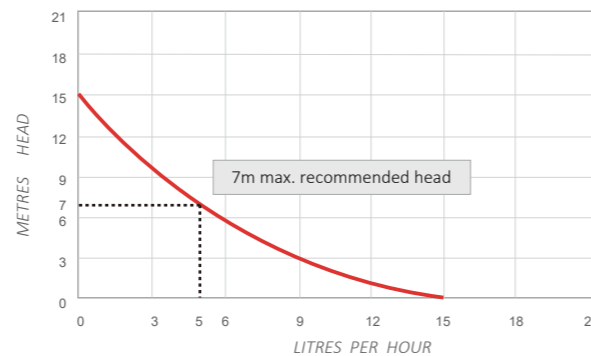

> IN THE BOX

- 1 Assembled SLIM BOX
- 2 6mm i/d vinyl tube
- 3 Assembled Inline reservoir
- 4 1.5m length of 6mm i/d vinyl tube
- 5 Inlet tube
- 6 Power cable
- 7 Self adhesive velcro strips x 2
- 8 4 x 200mm x 4mm cable ties

DIMENSION <

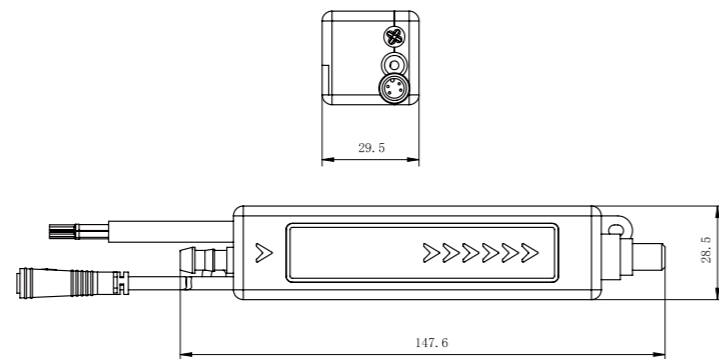

EASY BOX



CONDENSATE PUMP

- Plug & Play
- Anti-vibration
- Quiet Operation
- Small size suitable for various installation

- Max. flow 15L/h (4.0GPH) @ 0 head
- Sound level < 21 dB(A) @ 1M (3.3ft)
- Max. discharge head 12 M (39.4ft)

> TECHNICAL DATA

- Power supply: 115V 50Hz or 230V 50/60Hz
- Max. flow: 15L/h (4GPH) @ 0 head
- Sound level: 21 dB(A) @ 1M (3.3ft)
- Max. discharge head: 12M (39.4ft)
- Tank capacity: 40ml
- Max. unit output: 16kw / 54,600 Btu/h
- Max. water temperature: 40°C
- Discharge tube: 6mmID
- Class: II appliance
- Rated: Non continuous
- IP Protection: IPX5
- Thermal protection: Yes
- Fully potted: Yes
- LxWxH: 82.4mm x 28mm x 37mm

TYPICAL PERFORMANCE <

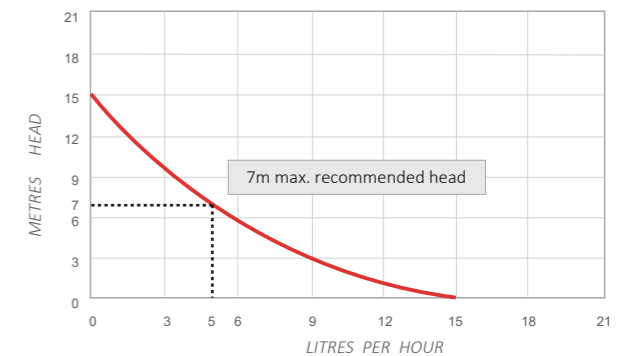

> IN THE BOX

- 1 Assembled EASY BOX
- 2 6mm i/d vinyl tube
- 3 Assembled Inline reservoir
- 4 Inlet tube
- 5 Power cable
- 6 Self adhesive velcro strips x 2
- 7 2 x 100mm x 3mm cable ties

DIMENSION <

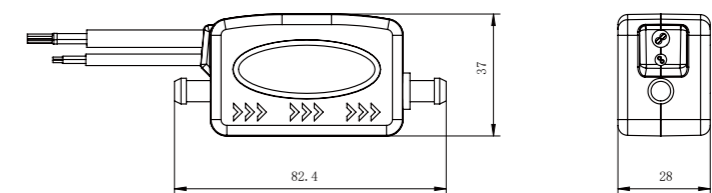

MINI BOX



CONDENSATE PUMP

- Plug & Play
- Anti-vibration
- Quiet Operation
- Small size suitable for various installation

- 🔥 Max. flow 10L/h (2.6GPH) @ 0 head
- 🔊 Sound level < 20dB(A)@ 1M (3.3ft)
- 📏 Max. discharge head 15M (49.2ft)

> TECHNICAL DATA

- Max. flow: 10L/h (2.6 GPH) @ 0 head
- Sound level: 20 dB(A)@1M (3.3ft)
- Power supply: 100-240V AC 50/60Hz
- Max. discharge head: 15M (49.2ft)
- Max. unit output: 16kw/54,600Btu/h
- Safety switch: 3A Normally closed
- Max. water temperature: 70 °C
- Discharge tube: 6mmID
- Class: II appliance
- Rated: Continuous
- IP Protection: IPX4

TYPICAL PERFORMANCE <

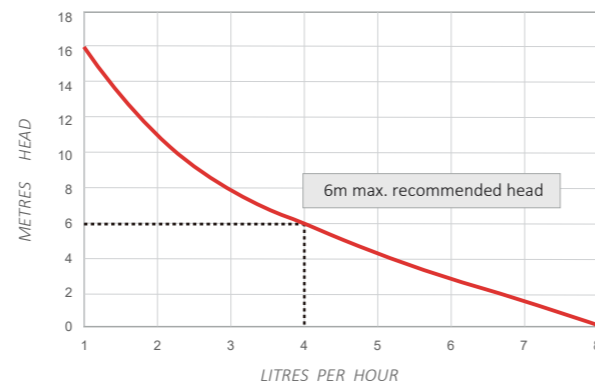

> IN THE BOX

- 1 Assembled maxi box pump
- 2 6mm i/d vinyl tube
- 3 Assembled Inline reservoir
- 4 1.5m length of 6mm i/d vinyl tube
- 5 Inlet tube
- 6 2 x self adhesive velcro strips
- 7 4 x 200mm x 4mm cable ties
- 8 Anti-siphon valve
- 9 Check valve

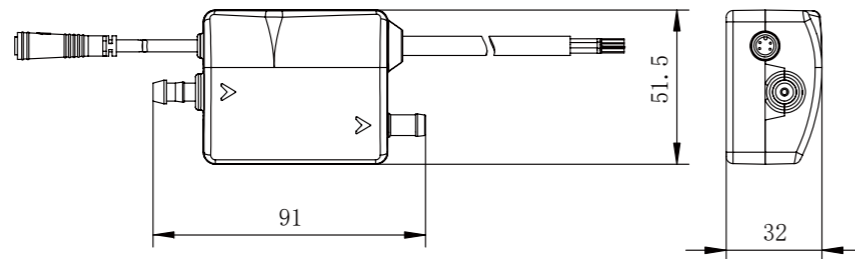

DIMENSION <

MAXI BOX



CONDENSATE PUMP

- High Performance
- Plug & Play
- Anti-vibration
- Quiet Operation

- 🔥 Max flow 40L/h (10.6GPH) @ 0 head
- 🔊 Sound level < 20dB(A)@ 1M (3.3ft)
- 📏 Max. discharge head 20M (65.6ft)

> TECHNICAL DATA

- Max. flow: 40L/h (10.6GPH) @ 0 head
- Sound level: 20 dB(A) @1M (3.3ft)
- Power supply: 100-240V AC 50/60Hz
- Max. discharge head: 20M (65.6ft)
- Max. unit output: 46kw/157,000Btu/h
- Safety switch: 3A Normally closed
- Max. water temperature: 70 °C
- Discharge tube: 6mmID
- Class: II appliance
- Rated: Continuous
- IP Protection: IPX4

TYPICAL PERFORMANCE <

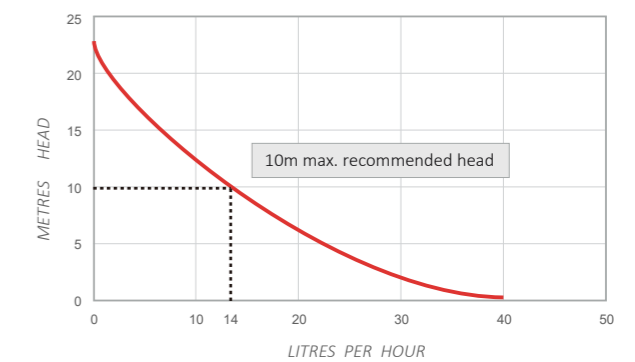

> IN THE BOX

- 1 Assembled maxi box pump
- 2 6mm i/d vinyl tube
- 3 Assembled Inline reservoir
- 4 1.5m length of 6mm i/d vinyl tube
- 5 Inlet tube
- 6 2 x self adhesive velcro strips
- 7 4 x 200mm x 4mm cable ties
- 8 Anti-siphon valve
- 9 Check valve

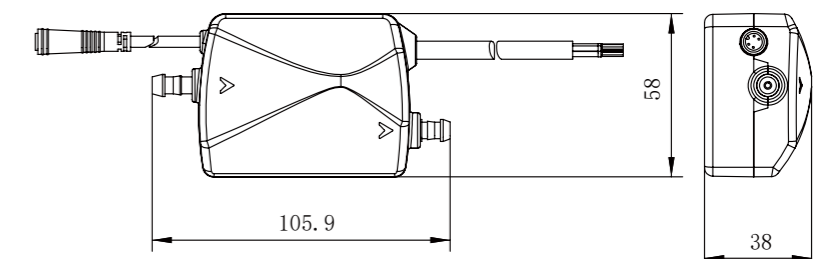

DIMENSION <

MPC-20



CONDENSATE PUMP

- Plug & Play
- Anti-vibration
- Quiet Operation
- Fit various installation methods

- Max. flow 20L/h (5.3GPH) @ 0 head
- Sound level < 18 dB(A) @ 1M
- Max. discharge head 20M (65.6ft)

> TECHNICAL DATA

- Power supply: 100-240V AC 50/60Hz
- Max. flow: 20L/h (5.3GPH) @ 0 head
- Sound level: 18 dB(A) @1M (3.3ft)
- Max. discharge head: 20M (65.6ft)
- Max. unit output: 28kw / 95,550 Btu/h
- Safety switch: 3A Normally closed
- Max. water temperature: 70°C
- Discharge tube: 6mmID
- Class: II appliance
- Rated: Continuous
- LxWxH: 125mm x 38mm x 50mm

TYPICAL PERFORMANCE <

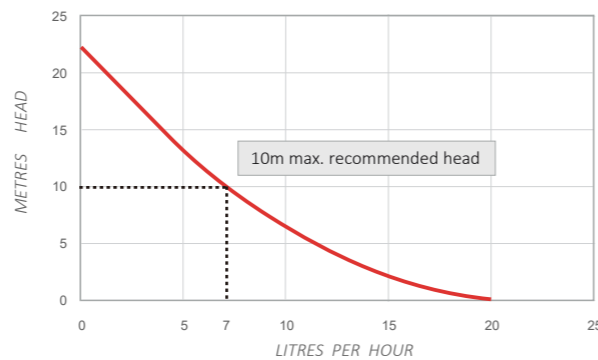

> IN THE BOX

- 1 Assembled MPC PUMP
- 2 6mm i/d vinyl tube
- 3 Assembled Inline reservoir
- 4 1.5m length of 6mm i/d vinyl tube
- 5 Inlet tube
- 6 6 pin socket lead assembly
- 7 Self adhesive velcro strips x 2
- 8 4 x 200mm x 4mm cable ties
- 9 Check valve
- 10 Anti-siphon valve

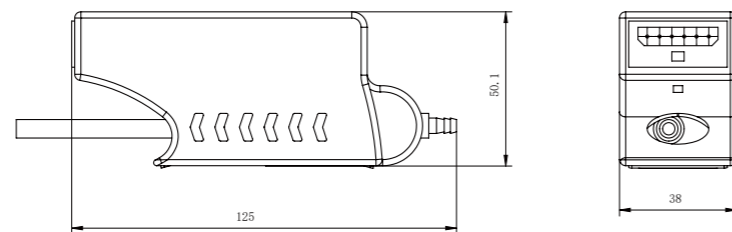

DIMENSION <

MPC-40



CONDENSATE PUMP

- High Performance
- Plug & Play
- Anti-vibration
- Quiet Operation
- Fit various installation methods

- Max flow 40L/h (10.6GPH) @ 0 head
- Sound level < 20 dB(A) @ 1M (3.3ft)
- Max. discharge head 20M (65.6ft)

> TECHNICAL DATA

- Power supply: 100-240V AC 50/60Hz
- Max. flow: 40L/h (10.6GPH) @ 0 head
- Sound level: 20 dB(A) @1M (3.3ft)
- Max. discharge head: 20M (65.6ft)
- Max. unit output: 46kw / 157,000 Btu/h
- Safety switch: 3A Normally closed
- Max. water temperature: 70°C
- Discharge tube: 6mmID
- Class: II appliance
- Rated: Continuous
- LxWxH: 125mm x 38mm x 50mm

TYPICAL PERFORMANCE <

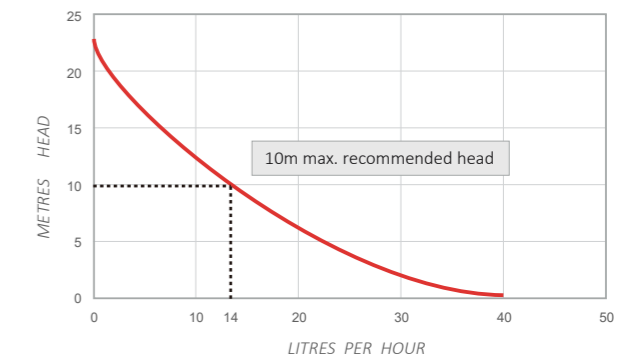

> IN THE BOX

- 1 Assembled MPC PUMP
- 2 6mm i/d vinyl tube
- 3 Assembled Inline reservoir
- 4 1.5m length of 6mm i/d vinyl tube
- 5 Inlet tube
- 6 6 pin socket lead assembly
- 7 Self adhesive velcro strips x 2
- 8 4 x 200mm x 4mm cable ties
- 9 Check valve
- 10 Anti-siphon valve

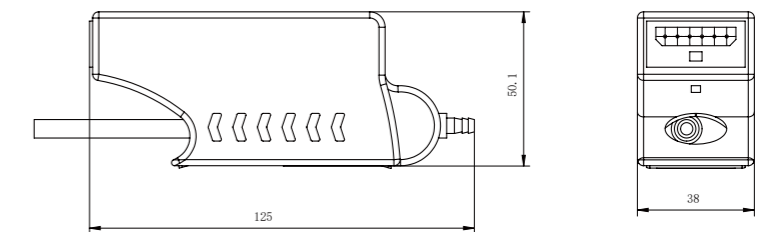

DIMENSION <

PC-DC



> TECHNICAL DATA

- Max. flow rate: 70L/h
- Rated voltage: DC12V(1±10%)
- Rated max head: 1.2M
- Water level: 10mm
- Input power: 2.4W(1±10%)
- Rated flow rate: >550ml/min

TYPICAL PERFORMANCE <

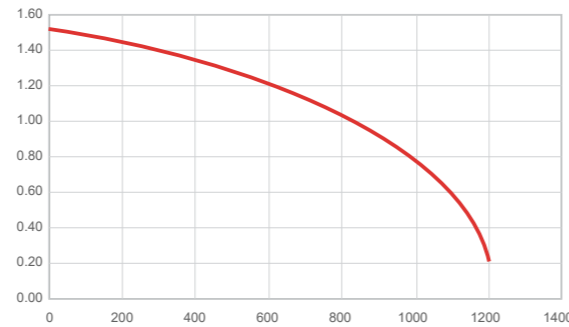

> DIMENSION

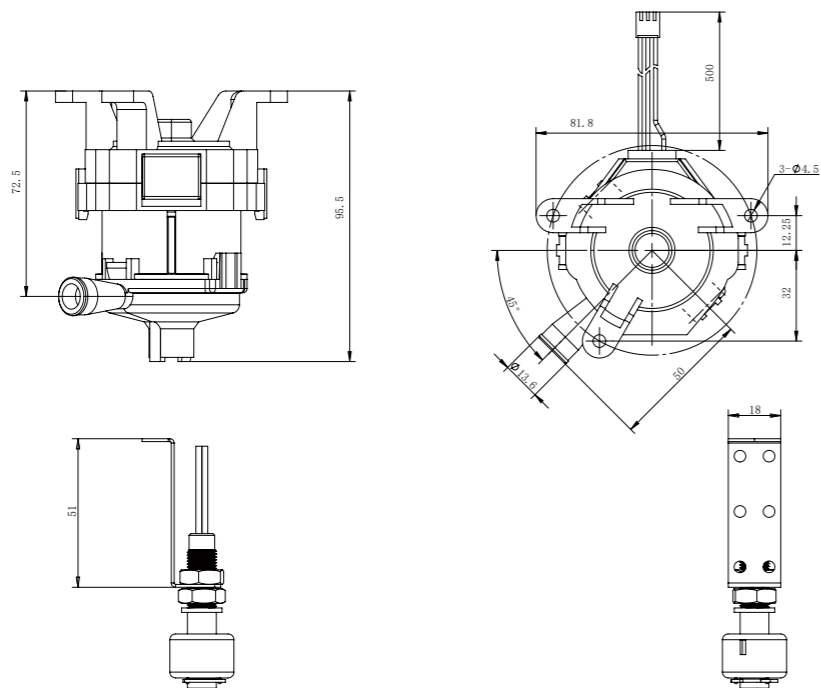

PC-AC



> TECHNICAL DATA

PC-AC40

- Max. flow rate: 40L/h
- Max. discharge height: 95cm
- Power supply: 230V-50/60 Hz≤8W
- Alarm contact: NC 50 VA resistive-250V
- Input power: impedance protection
- Alarm level: 18mm
- Sound level at 1 m: ≤30dBA

TECHNICAL DATA <

PC-AC70

- Max. flow rate: 70L/h
- Max. discharge height: 95cm
- Power supply: 230V-50/60 Hz≤8W
- Alarm contact: NC 50 VA resistive-250V
- Input power: impedance protection
- Alarm level: 18mm
- Sound level at 1 m: ≤35dBA

> DIMENSION

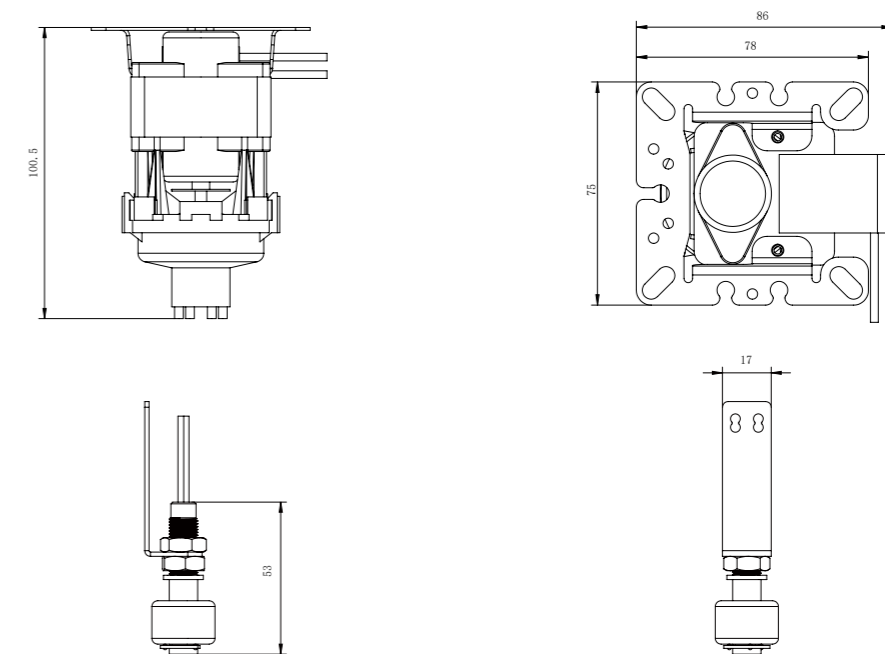

TANK-V

Tank capacity: 2.2L (0.6 gallon)

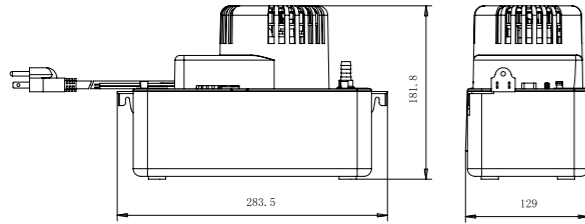

TANK-L

Tank capacity: 1.1L (0.3 gallon)

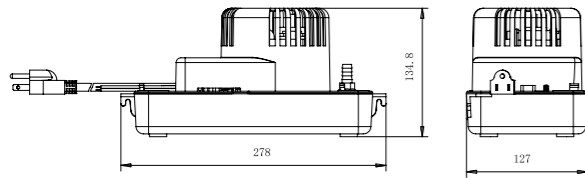

Model	Voltage(V)	Frequency(Hz)	Current(A)	Power(W)	Max. flow	Max. discharge head
RTP15WS115V RTP15WS115L	115	60	1.0	60	66GPH (250L/H)	15'/4.6M
RTP20WS115V RTP20WS115L	115	60	1.5	85	80GPH (303L/H)	20'/6.1M
RTP22WS115V RTP22WS115L	115	60	1.85	100	145GPH (550L/H)	22'/6.7M
RTP24WS115V RTP24WS115L	115	60	2.2	110	153GPH (580L/H)	24'/7.3M
RTP15WS230V RTP15WS230L	230	60	0.45	50	66GPH (250L/H)	15'/4.6M
RTP20WS230V RTP20WS230L	230	60	0.55	75	80GPH (303L/H)	20'/6.1M
RTP22WS230V RTP22WS230L	230	60	1.0	100	145GPH (550L/H)	22'/6.7M
RTP24WS230V RTP24WS230L	230	60	1.1	110	153GPH (580L/H)	24'/7.3M
RTP15WS230V RTP15WS230L	230	50	0.6	60	251L/H	4M
RTP20WS230V RTP20WS230L	230	50	0.7	85	265L/H	4.5M
RTP22WS230V RTP22WS230L	230	50	1.2	115	268L/H	5M
RTP24WS230V RTP24WS230L	230	50	1.3	125	352L/H	5.5M

Tank-X

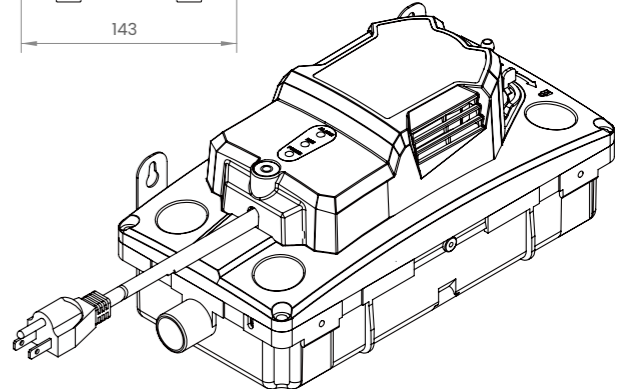
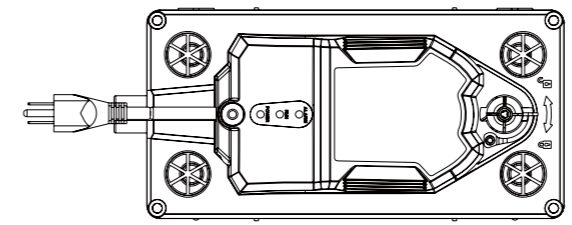
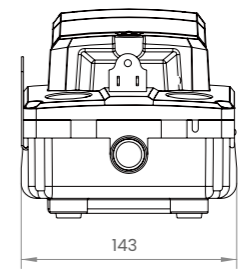
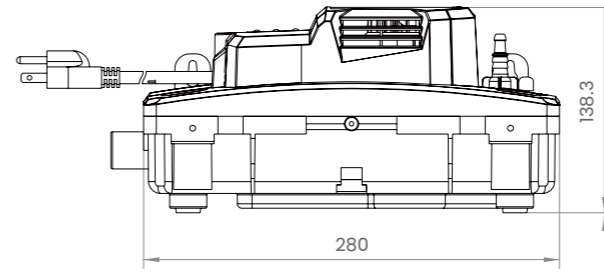

Model	Voltage(V)	Frequency(Hz)	Current(A)	Power(W)	Max. flow	Max. discharge head
TKX20WS115	115	60	1.5	85	80GPH (303L/H)	20'/6.1M
TKX20WS230	230	60	0.55	75	80GPH (303L/H)	20'/6.1M
	230	50	0.7	85	265L/H	4.5M

INLINE RESERVOIR

Assembled inline reservoir includes:

- lid & sensor cable
- float
- filter
- reservoir



IR1

ANTI-SIPHON JOINT

Prevent siphon; Used in Tranquil, Mute, and some of Box series pumps



ASJ1

CHECK VALVE

Unidirectional adaptor



CV1

MAGNET FLOAT

Used in Mute & Box Series Pumps



MF1

INLET FILTER

Prevent dirt from entering the pump directly



IF1

INLET HOSE

Customizable Lengths per Request



IH1

PLASTIC CABLE TIES

Hold tubes firmly in place to prevent movement, vibration, and sagging.



PCT1

VINYL TUBING

Flexible, corrosion-resistant and aging-resistant, safe and non-toxic; Customizable diameter and lengths



VT1

FLOAT SWITCH-FS1

TECHINICAL DATA

Voltage: 24VAC
 Current: 1.25 Amp
 General Purpose, Used in Class 2 (Thermostat) Circuit Only

- Automatically detects clogged A/C condensate drains and shuts off the system for enhanced safety protection.
- Accommodates sloped drain line installation up to 45 degrees.
- Cap can be easily removable for inspecting the operation of float switches.



FLOAT SWITCH-FS2

TECHINICAL DATA

Voltage: 24VAC
 Current: 1.25 Amp
 General Purpose, Used in Class 2 (Thermostat) Circuit Only

- Automatically detects clogged A/C condensate drains and shuts off the system for enhanced safety protection.
- Installed horizontally on the auxiliary drain outlet of the primary pan, using the provided adapter, bushing, and cap.
- Cap can be easily removable for inspecting the operation of float switches.



FLOAT SWITCH-FS3

TECHINICAL DATA

Voltage: 24VAC
 Current: 1.25 Amp
 General Purpose, Used in Class 2 (Thermostat) Circuit Only

- Automatically detects clogged A/C condensate drains and shuts off the system for enhanced safety protection.
- Engineered with heavy-duty steel mounting brackets for secure attachment to condensate drain pan.
- Installed on various primary or auxiliary drain pans and will operate correctly even if the installation is off-center.



CTK

Condensate Trap Kit with Overflow Switch

Voltage: 24VAC
 Current: 1.25 Amp
 General Purpose, Used in Class 2 (Thermostat) Circuit Only

Code	Size
CTK1	1"
CTK2	3/4"

- Automatically detects clogged A/C condensate drains and shuts off the system for enhanced safety protection.
- Accommodates sloped drain line installation up to 45 degrees.
- Cap can be easily removable for inspecting the operation of float switches.



CT-MSP1

Voltage: 24VAC
 Current: 4 Amp

Universal inline primary/secondary overflow switch, designed for horizontal installation.



CT-MSP2

Voltage: 24VAC
 Current: 4 Amp

Universal inline primary/secondary overflow switch, designed for horizontal and vertical installation.



CT-MS1

TECHINICAL DATA

Power: 24VAC
Current: 4A

- Microswitch technology (4A NO/NC) for high switching capacity
- Transparent design for easy cleaning and inspection
- Watertight blue caps for quick drainage access
- Consists of durable 3/4" PVC fittings
- Smart trap switch warns of blockages and shuts down the unit; removable for cleaning



CT-MS2

TECHINICAL DATA

Power: 24VAC
Current: 4A

- Microswitch technology (4A NO/NC) for high switching capacity
- Transparent design for easy cleaning and inspection
- Watertight blue caps for quick drainage access
- Consists of durable 3/4" PVC fittings
- Smart trap switch warns of blockages and shuts down the unit; removable for cleaning
- Threads into fitting on secondary drain pan



CT-MS3

TECHINICAL DATA

Power: 24VAC
Current: 4A

- Microswitch technology (4A NO/NC) for high switching capacity
- Transparent design for easy cleaning and inspection
- Trap kit includes 3/4" clear trap, 3/4" tee with caps, 3/4" cross with caps, micro switch, and a clear brush



CT

Code	Size
CT1	3/4"
CT2	1"

- The trap's clear design enables effortless cleaning and inspection.
- Equipped with watertight blue caps, ensuring easy access for cleaning both the trap and the drain pan outlet.
- Provided with brush (optional)



CO2 SHOT DRAIN GUN

A/C drain line flush to clean condensate drain lines faster and easier

- Compatible with CO2 Cartridges in a pack of 6 or 12
- Tapered fitting to cleaning for 3/8 in - 3/4 in drain openings
- Portable, light-weight, and eco-friendly



WET SWITCH FD-1

- Automatically cut off the power line/equipment with detection of presence of water
- LED indicators display operating status
- Flexible installations; usually placed in a drain pan, or on floor
- Manual reset for multiple uses
- Easy and quick installation



Rated Current	Rated Voltage	Electrical Connection Type	Switch
3A	12-30VAC 50/60Hz or 12-36VDC	Independently powered	Normally closed (N/C) Normally open (N/O)

SURGE PROTECTIVE DEVICE - R-SP

One Simple Investment to Ensure Lasting Comfort at Home

The green LED light will be on when the SPD is functioning properly. When the red LED light is on, it signals reduced protection and indicates that the device should be replaced

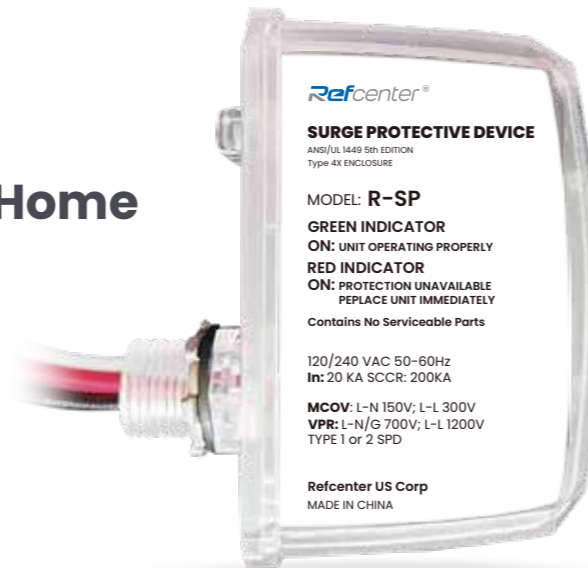

R-SP Protects:

- Ductless Mini-splits
- Central Air Conditioners
- Heat Pumps
- Furnaces
- Boilers
- ECM Motors
- Home Appliances

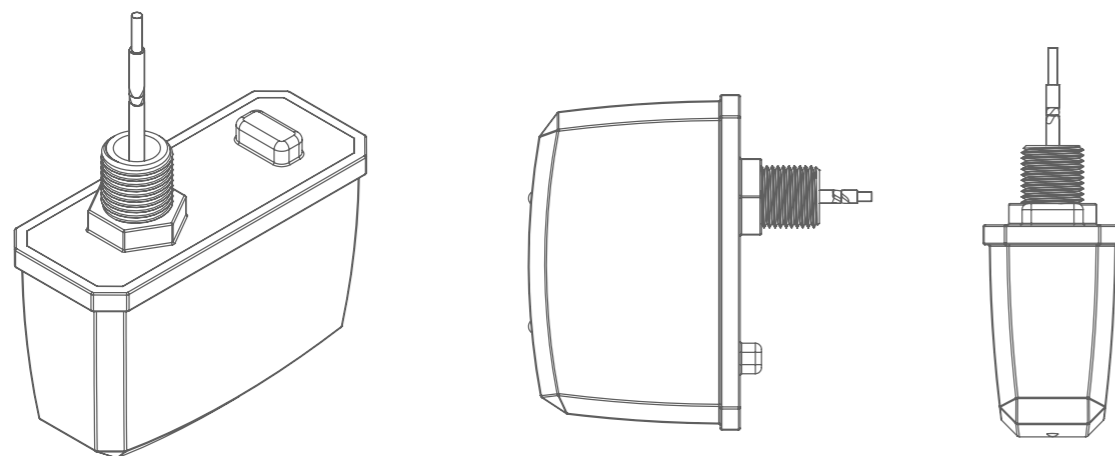

SURGE PROTECTIVE DEVICE

Features

- Modes of protection: 3(L1-N, L2-N, L1-L2)
- Easy installation to disconnect box or junction box
- Type 4X Enclosure
- TPMOV® Technology
- LED Indicators. Green: unit operating correctly Red: protection diminished. replace unit.
- Mounting feet for stability
- Weather-Rated NEMA 4X
- ANSI/UL 1449 5th EDITION
- Max continuous overvoltage L-N 150V /L-L300V
- Voltage protection rating L-N 700V/ L-L1200V

Specifications

Input Voltage:	120/240 VAC
Frequency:	50-60Hz
SPD Type:	Type 1 or Type 2
MCOV:	L-N/G: 150 V, L-L: 300 V
VPR:	L-N/G: 700 V, L-L: 1200 V
Nominal Discharge Rating:	20 kA
Short Circuit Current Rating:	200 kA
Operating Temp:	-40° F to 158° F (-40° C to 70° C)
Enclosure:	Type 4X Outdoor

VINYL TUBING



Code	35CF101	35CF102	35CF103	35CF104	35CF105
Size	1/4"	3/8"	1/2"	5/8"	1"
Diameter ID (mm)	6	10	12	15	25
Diameter OD (mm)	9	14	16	20	31
Length per roll (m)	6/20/25/50m or 10/25/50/100ft				
Material	PVC				
Temperature (°C)	10-60				

BRAIDED VINYL TUBING



Code	36CF101	36CF102	36CF103	36CF104	36CF105
Size	1/4"	3/8"	1/2"	5/8"	1"
Diameter ID (mm)	6	10	12	15	25
Diameter OD (mm)	9	14	16	20	31
Length per roll (m)	30m or 100ft or customized				
Material	PVC				
Temperature (°C)	5-60				

SMOOTH DRAIN LINE



Code	31CF301	31CF302	31CF303	31CF304	31CF305
Diameter (mm)	12	16 (5/8")	19 (3/4")	20	25 (1")
Length per roll (m)	20/25 or customized				
Color	RAL9002, RAL9003, or customized				

PVC REINFORCED TUBING



Code	81CF101	81CF102	81CF103	81CF104	81CF105	81CF105
Diameter OD (mm)	16	18	20	25	32	40
Thickness (mm)	2					
Color	White - RAL 9003					
Length per roll (m)	20/25 or customized					
Temperature (°C)	0-70					

Code	81CF201	81CF202	81CF203	81CF204	81CF205	81CF205
Diameter OD (mm)	16	18	20	25	32	40
Thickness (mm)	2					
Color	Grey - RAL9006					
Length per roll (m)	20/25 or customized					
Temperature (°C)	0-70					

CORRUGATED TUBING



Code	31CF101	31CF102	31CF103	31CF104	31CF105	31CF106	31CF107	31CF108
OD (mm)	19/21	21	19/21	21	19/21	21	19/21	21
ID(mm)	16/18 (5/8")	18/20	16/16-18/18	18/18-20/20	16/18	18/20	16/16-18/18	18/18-20/20
Single/Double Layer	Single	Single	Single	Single	Double	Double	Double	Double
Length per roll (m)	6/8/15/50m or 20/160ft or customized							
Stretch(m)	0.5/1							
Color	RAL 1013 or customized							
Material	Polyethylene							

INSULATED DRAIN HOSE



Code	31CF401	31CF402	31CF403	31CF404
Size	5/8"	3/4"	1"	1-1/4"
Diameter ID (mm)	16	19	25	32
Diameter OD (mm)	23.5	26.5	33	40
Length per roll (m)	5/10/20			
Material	PVC, Polypropylene (PP), and Polyethylene (PE)			
Color	white/grey			
Temperature (°C)	0-70			

ACB-A

Material	Galvanized Steel
Color	RAL9002 / Pantone 7534C
Finish	Epoxy Polyester Powder
Accessories	8x80mm Lag Screw (6) 10mm Concrete Anchor (6) 1" Bolt (4) Clip Nut (4) Rubber Mount (4)

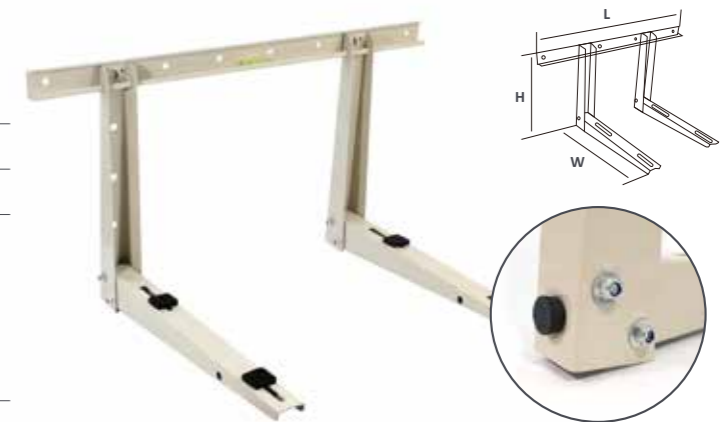

Code	HxWxL (mm)	Thickness (mm)	Load (kg)
ACB-A01	450x560x850	2	200
ACB-A02	450x600x850	2	200

ACB-B

Material	Cold Press Steel / Galvanized Steel
Color	RAL9016
Finish	Epoxy Polyester Powder
Accessories	Plastic anchor bolts (5) Nut M8*30 (4) Wood screw M8*65 (5) Rubber mat (4) Metal washer M8 (5) Adjustable screws (2) Bolt M8*25 (4) Connecting screws (2) Metal Washer M8 (4) Spirit level (1)



Code	HxWxL (mm)	Thickness (mm)	Load (kg)
ACB-B01	350x420x800	1.5	150
ACB-B02	350x450x800	1.5	150
ACB-B07	375x420x800	1.5	150
ACB-B08	375x460x800	1.5	180
ACB-B03	375x550x800	1.5	180
ACB-B09	390x420x800	1.5	180
ACB-B04	350x420x800	1.8	180
ACB-B05	350x450x800	1.8	180
ACB-B06	350x550x800	1.8	180
ACB-B10	375x420x800	1.8	180
ACB-B11	390x550x800	1.8	180
ACB-B12	450x550x800	1.8	180
ACB-B13	375x420x800	2.0	200
ACB-B14	390x550x800	2.0	200
ACB-B15	450x550x800	2.0	200

ACB-C

Material	Cold Press Steel / Galvanized Steel
Color	RAL9016
Finish	Epoxy Polyester Powder
Accessories	Expansion bolts (4) Rubber mat (4) Bolts, nuts and washers

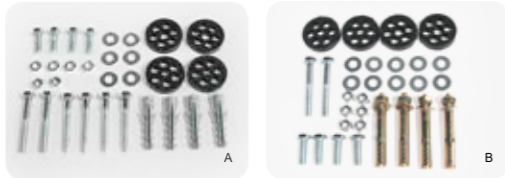
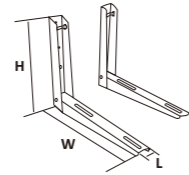

Code	HxWxL (mm)	Thickness (mm)	Load (kg)
ACB-C01	390x450x50	1.5	150
ACB-C02	390x500x50	1.5	150
ACB-C03	400x500x50	1.5	180
ACB-C04	390x450x50	1.8	180
ACB-C05	390x550x50	1.8	180
ACB-C06	450x550x50	1.8	180
ACB-C07	450x500x50	2.0	200
ACB-C08	450x550x50	2.0	200

ACB-D

Material	Cold Press Steel / Galvanized Steel
Color	Ivory
Finish	Epoxy Polyester Powder
Accessories	Anti-vibrator SG40

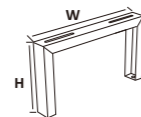

Code	HxW (mm)	Thickness (mm)	Load (kg)
ACB-D01	400x250	2	200
ACB-D02	460x250	2	200

ACB-E

Material	Cold Press Steel / Galvanized Steel
Color	RAL1013, RAL9002
Finish	Epoxy Powder
Accessories (optional)	Expansion bolts Bolts, nuts and washers

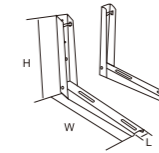

Code	HxWxL (mm)	Thickness (mm)	Load (kg)
ACB-E01	500x400x60	2	200
ACB-E02	500x450x60	2	200
ACB-E03	500x500x60	2	200
ACB-E04	500x600x60	2	200
ACB-E05	1000x600x60	1.5	150
ACB-E06	500x400x50	1.5	150
ACB-E07	500x450x50	1.5	150
ACB-E08	500x500x50	1.5	150
ACB-E09	500x600x50	1.5	150
ACB-G01	500x400x60	1.5	150
ACB-G02	500x450x60	1.5	150
ACB-G03	500x500x60	1.5	150
ACB-G04	500x600x60	1.8	180

ACB-F

Material	Cold Press Steel / Galvanized Steel
Color	RAL1013, RAL9002
Finish	Epoxy Powder
Accessories (optional)	Expansion bolts Bolts, nuts and washers

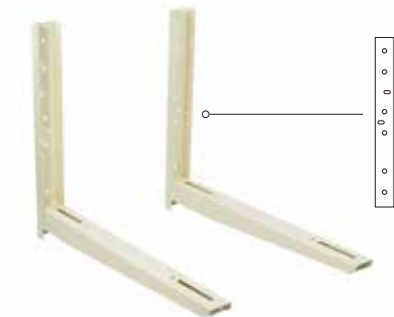
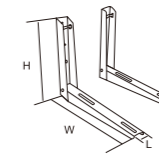

Code	HxWxL (mm)	Thickness (mm)	Load (kg)
ACB-F01	500x400x60	1.5	150
ACB-F02	500x450x60	1.5	150
ACB-F03	500x500x60	1.5	150
ACB-F04	500x600x60	1.8	180
ACB-F05	1000x600x60	3	300
ACB-F201	500x400x50	1.5	150
ACB-F202	500x450x50	1.5	150
ACB-F203	500x500x50	1.5	150
ACB-F204	500x600x50	1.8	180

ACB-J

Material	Cold Press Steel / Galvanized Steel
Accessories	Bolts Nuts Metal washer Rubber pads (4)

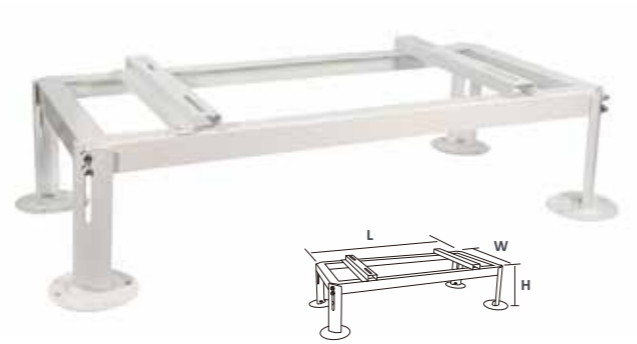

Code	HxWxL (mm)	Load (kg)
ACB-J01	380x400x850	100
ACB-J02	480x400x850	100
ACB-J03	550x420x850	200
ACB-J04	600x500x1000	200

ACB-H

Material	Cold Press Steel / Galvanized Steel
Color	RAL9016
Finish	Epoxy Polyester Powder
Accessories	Expansion bolts (4) Rubber mat (4) Bolts, nuts and washers

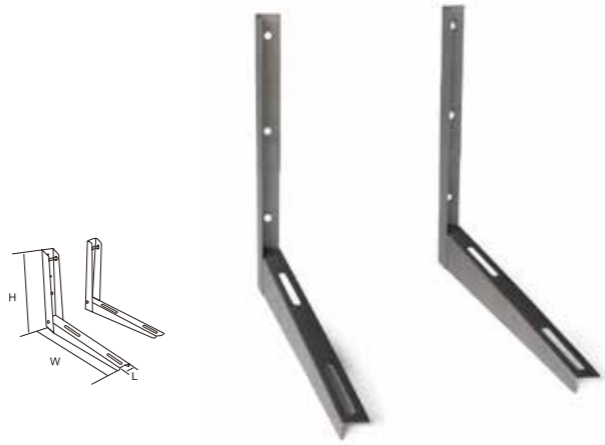

Code	HxWxL (mm)	Thickness (mm)	Load (kg)
ACB-C01	410x450x1.5mm	1.5	120
ACB-C02	410x450x1.8mm	1.5	150
ACB-C03	410x450x2mm	2	180

21CF74

Material	Cold Press Steel / Galvanized Steel
Color	RAL9002
Finish	Epoxy Polyester Powder
Accessories	Bolts, nuts and washers Rubber Pads (4) Spirit level (1)

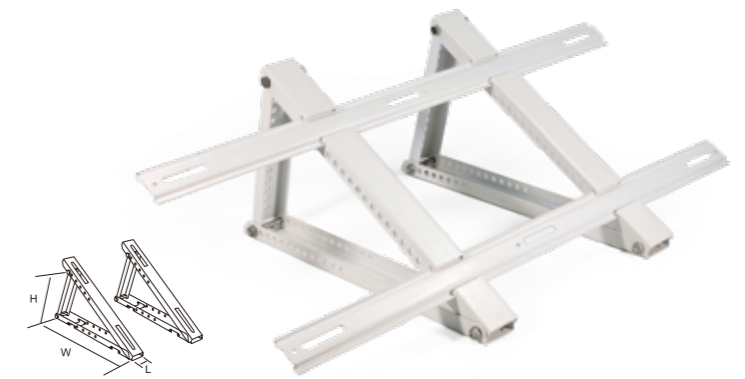

Adjusted angle (degrees) 20-35

Code	HxWxL (mm)	Thickness (mm)	Load (kg)
21CF741	250x450x800	1.8	150-200

ACR-A

Applicable Scope	7500Btu-24000Btu A/C
Load per Kit (kg)	150

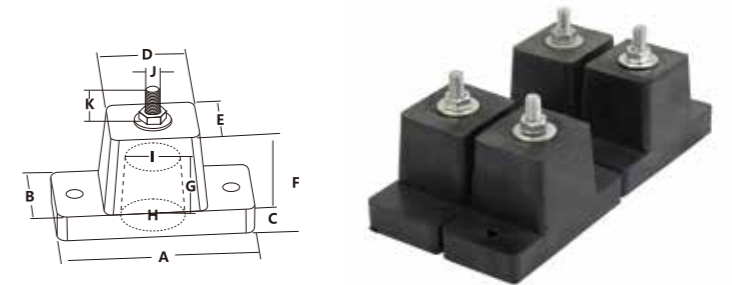

Code	A	B	C	D	E	F	G	H	I	J	K
ACR-A	95	47	16	47	41	40	32	35	30	8	20

ACR-B

Applicable Scope	7500Btu-24000Btu A/C
-------------------------	----------------------

Code	Size (mm)	Load per kit (kg)
ACR-B01	105x45x75	120
ACR-B02	105x45x100	150



ACR-C

Applicable Scope 7500Btu-24000Btu A/C

Code	Size (mm)	Load (kg)
ACR-C01	100x57x50	150



ACR-D

Applicable Scope 7500Btu-24000Btu A/C

Load per Kit (kg) 200

Code	Size (mm)	Color
ACR-D01	DIA100x90	black
ACR-D02	DIA100x90	white



ACR-E

Material Polypropylene

Color Ivory

Accessories (optional) Anti-slip EVA tape
Bolts and Nuts

Code	Size (mm)	Load per kit (kg)
ACR-E01	100x100x90	200



FLOOR SUPPORT-1

Material	PVC
Color	Ivory
Accessories (optional)	Screws M10*32 (2) Nuts M10 (2) Washers M10 (2) Rubber or Foam Tape



Code	Length (mm)	Color	Load (kg)
22CF101	350	Ivory	300
22CF102	450	Ivory	300
22CF103	1000	Ivory	300
22CF104	350	Black	300
22CF105	450	Black	300
22CF106	1000	Black	300



FLOOR SUPPORT-2B

Light weight, anti vibration and easy installation



Code	Size (mm)	Color	Load (kg)
22CF202B	450*75*120	Ivory	140

FLOOR SUPPORT-3

Light weight, anti vibration and easy installation



Code	Length (mm)	Color	Load (kg)
22CF301	350	black	140
22CF302	450	black	140
22CF303	1000	black	140
22CF304	350	ivory	140
22CF305	450	ivory	140
22CF306	1000	ivory	140

FLOOR SUPPORT-4A



Code	Length (mm)	Load (kg)	Accessories
22CF401A	250x130x50	200	screw kits x2
22CF402A	400x130x50	200	screw kits x4

FLOOR SUPPORT-4C

- Designed to provide a stable and secure base for A/C equipments
- With aluminum profile. Install with steel fixing screws and spirit levels



Code	Size(mm)	Load (kg)	Accessories
22CF401C	250x180x95	200	screw kits x2
22CF402C	400x180x95	250	screw kits x4
22CF403C	600x180x95	250	screw kits x4
22CF404C	1000x180x95	300	screw kits x4

FLOOR SUPPORT-4D

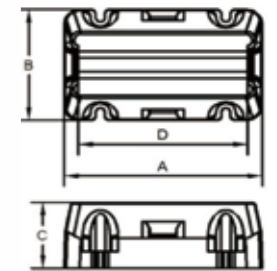

Code	AxBxCxD(mm)	Weight (kg/kit)	Load per kit (kg)	pcs per kit	Accessories
22CF401D	250x163x98x210	4.87	220	2	screw kits x2
22CF402D	400x163x98x360	7.33	320	2	screw kits x4
22CF403D	450x163x98x410	8.21	350	2	screw kits x4
22CF404D	500x163x98x460	9.1	380	2	screw kits x4
22CF405D	600x163x98x560	10.86	500	2	screw kits x4
22CF406D	1000x163x98x960	17.93	800	2	screw kits x4

EP

- Plastic pad designed as a mounting base for air conditioner condensers
- Composed of recycled and UV-resistant Polypropylene for sustainability

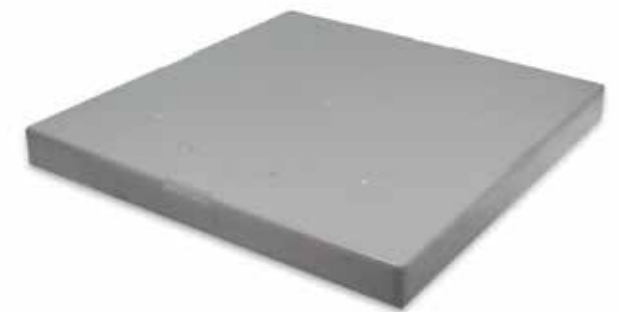

Code	Size(inch)
EP-01	24x24x3
EP-02	32x32x3
EP-03	36x36x3
EP-04	38x18x3

ANTI-VIBRATOR

Anti-vibrators in AC installation minimize vibrations and noise generated by the compressor and other moving parts, ensuring smoother operation and extending the lifespan of the system. They also protect surrounding structures and components from potential damage caused by continuous vibrations. 4 pieces in one kit.

AG35

Code	Size (mm)	Load per kit (kg)
51CF101	35x25 M8	100
51CF101S	40x20 M8	50

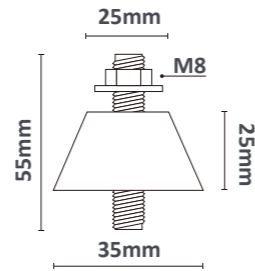

AG45

Code	Size (mm)	Load per kit (kg)
51CF102	45x30 M8	150
51CF102S	40x20 M8	80

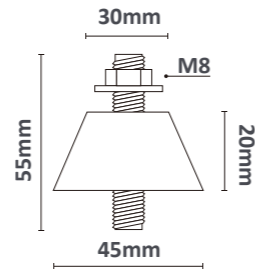

SG40

Code	Size (mm)	Load per kit (kg)
51CF201	48x40 M8	100

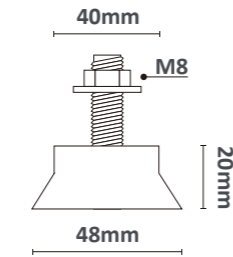

SG60

Code	Size (mm)	Load per kit (kg)
51CF301	56x52 M10	150

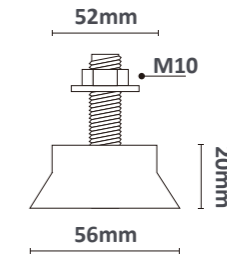

AA30

Code	Size (mm)	Load per kit (kg)
51CF401	30x20 M8	90

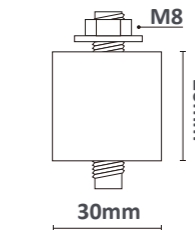

AA40

Code	Size (mm)	Load per kit (kg)
51CF402	40x40 M8	150
51CF403	40x30 M8	150

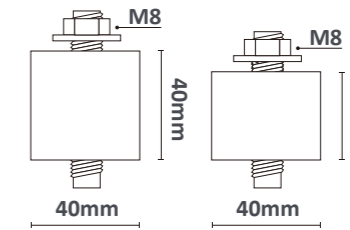

S26/S30

Code	Size (mm)	Load per kit (kg)
51CF501	35x20 M8	150
51CF502	40x40 M8	150

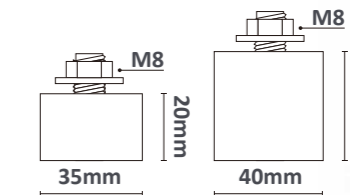

AT

Code	Size (mm)	Load per kit (kg)
51CF601	30x30 M8	100

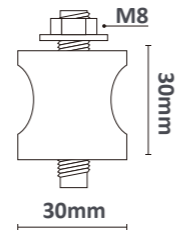

RUBBER/CORK ANTI-VIBRATION PAD

- Ideal for air conditioners, compressors, cooling towers, presses, machines, etc..
- High-quality elastomeric oil resistant padding.
- The cork is laminated between two corrugated pads.

Code	Size(mm)
22CF501	50x50x22.3 (2")
22CF502	75x75x22.3 (3")
22CF503	100x100x22.3 (4")
22CF504	150x150x22.3 (6")
22CF505	300x300x22.3 (12")
22CF506	450x450x22.3 (18")



EVA ANTI-VIBRATION PAD

- Tested against other pads at four different vibration settings
- Oil resistant and chemical resistant
- Much more effective at vibration dampening than solid rubber

Code	Size(mm)
22CF601	50x50x22.3 (2")
22CF602	75x75x22.3 (3")
22CF603	100x100x22.3 (4")
22CF604	150x150x22.3 (6")
22CF605	300x300x22.3 (12")
22CF606	450x450x22.3 (18")

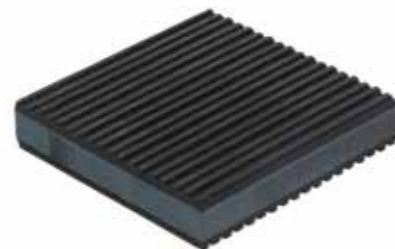

TAPE

Tapes are essential in AC installation for sealing joints, insulating components, and preventing air leaks, ensuring efficient system performance. They also help reduce noise, vibrations, and energy loss by providing secure and durable connections.

INSULATING SELF - ADHESIVE TAPE

With Mesh

Code	Size(mm)	Length(m)
14CF101M	50x3	10
14CF102M	50x3	15
14CF103M	50x3	25
14CF104M	100x3	10
14CF105M	100x3	15
14CF106M	100x3	25



INSULATING SELF - ADHESIVE TAPE

Without Mesh

Code	Size(mm)	Length(m)
14CF101	50x3	10
14CF102	50x3	15
14CF103	50x3	25
14CF104	100x3	10
14CF105	100x3	15
14CF106	100x3	25

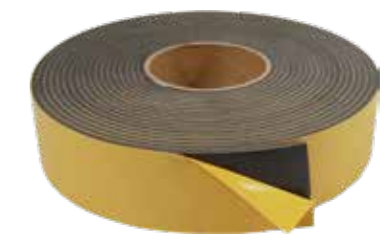

INSULATING NON-ADHESIVE TAPE

Code	Size(mm)	Thickness (mm)
15CF101	18x0.15	10



ALUMINUM FOIL DUCT TAPE- AFDT

Thickness (micron)	Width (mm)	Length (m)
20/30/40/50	50/75/100	30/50/100



PVC DUCT TAPE - PVCT

- PVC tape with an adhesive coat on one side.
- Usage temperature -10°C/+80°C
- Available in grey, white or black color and more

Thickness (mm)	Width (mm)
0.13/0.15/0.18	50/100



PRE-INSTALLATION BOX

A pre-installation box in AC installation simplifies the process by centralizing refrigerant lines, electrical wiring, and drainage, ensuring a clean and efficient setup. Commonly used in new constructions, it reduces installation time and maintains a professional appearance.

32CF101

- Horizontal outlet
- Equipped with elbow for vertical outlet

Code	Material	Dimension (mm)	Outlet
32CF101	ABS	385x128x60	Horizontal outlet



32CF102/103

- Horizontal outlet
- Including screw kit (6 screws)
- Optional elbow for vertical outlet

Code	Material	Dimension (mm)	Dimension (mm)
32CF102	ABS	428x105x70	Horizontal outlet
32CF103	ABS	428x105x70	Vertical outlet

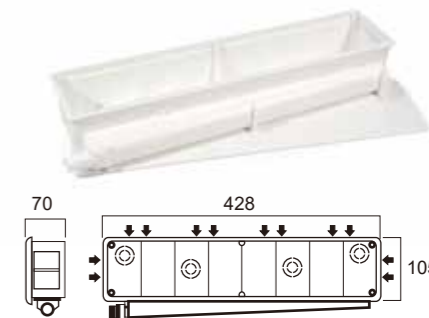

32CF104/105

- Vertical outlet
- Including screw kit (6 screws)
- Optional elbow for horizontal outlet

Code	Material	Dimension (mm)	Dimension (mm)
32CF104	ABS	428x105x52	Horizontal outlet
32CF105	ABS	428x105x52	Vertical outlet

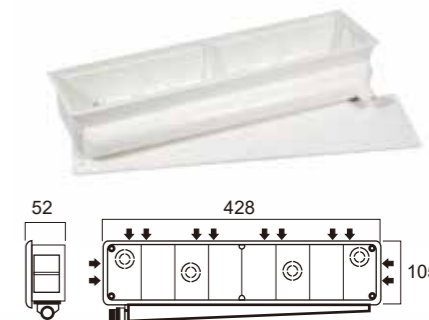

32CF106

- Vertical outlet
- Including screw kit (6 screws)
- Optional elbow for horizontal outlet

Code	Material	Dimension (mm)	Dimension (mm)
32CF106	ABS	485x128x65	Horizontal outlet

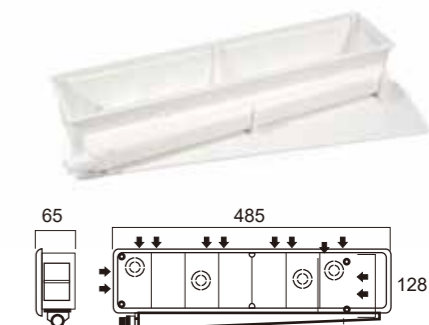

32CF108

- Box to fit in ABS with black cover
- Including screw kit

Code	Size(mm)
32CF108	400x180x60



32CF109

- Box to fit in ABS with black cover
- Including screw kit

Code	Size(mm)
32CF109	430x210x60



LINE SET COVERS

Line set covers in AC installation protect refrigerant lines, electrical wiring, and drain hoses from external elements like UV rays, moisture, and physical damage. They also enhance the system's appearance by providing a clean and organized finish to exposed components.

- UV resistance
- Easy installation
- Durable and low maintenance

STRAIGHT DUCT

Code	Material	Size(mm)
SD-01	PVC	75*65 (3")
SD-02	PVC	100*65 (4")
SD-03	PVC	130*90 (5")
SD-04	PVC	160*120 (6.25")



FLEX JOINT

Code	Material	Size(mm)
FJ-01	PE	75*65 (3")
FJ-02	PE	100*65 (4")
FJ-03	PE	130*90 (5")
FJ-04	PE	160*120 (6.25")



90° FLAT ELBOW

Code	Material	Size (mm)
FE-01	ABS	75*65 (3")
FE-02	ABS	100*65 (4")
FE-03	ABS	130*90 (5")
FE-04	ABS	160*120 (6.25")



DUCT END

Code	Material	Size (mm)
DE-01	ABS	75*65 (3")
DE-02	ABS	100*65 (4")
DE-03	ABS	130*90 (5")



90° ELBOW VERTICAL

Code	Material	Size (mm)
VE-01	ABS	75*65 (3")
VE-02	ABS	100*65 (4")
VE-03	ABS	130*90 (5")
VE-04	ABS	160*120 (6.25")



UNION COUPLING

Code	Material	Size (mm)
UC-01	ABS	75*65 (3")
UC-02	ABS	100*65 (4")
UC-03	ABS	130*90 (5")
UC-04	ABS	160*120 (6.25")



T JOINT

Code	Material	Size (mm)
TJ-01	ABS	100*65 (4")
TJ-02	ABS	130*90 (5")
TJ-03	ABS	160*120 (6.25")



SOFFIT FITTINGS

Code	Material	Size (mm)
SF-01	ABS	75*65 (3")
SF-02	ABS	100*65 (4")
SF-03	ABS	130*90 (5")



WALL PENETRATION

Code	Material	Size (mm)
WP-01	ABS	75*65 (3")
WP-02	ABS	100*65 (4")
WP-03	ABS	130*90 (5")
WP-04	ABS	160*120 (6.25")



AIR CONDITIONER INSTALLATION KIT - ACIK

ACCESSORIES:

1. Electric wire
2. Bracket
3. Copper insulation tube
4. PVC tape adhesive 0.13/0.14/0.15mm
5. PVC tape non-adhesive 0.13/0.14/0.15mm
6. Corrugated tube single/double layer
7. Wall sleeve
8. Wall cover ring
9. Seal
10. Nylon ties



PROTECTION COVER FOR EXTERNAL UNIT A - PCEA

- Oxford fabric+PU coating
- Sides secured with Velcro

Code	Dimension (LxWxH)
PCEA760	760x270x560
PCEA800	800x300x600
PCEA850	860x400x700
PCEA950	950x400x850



PROTECTION COVER FOR EXTERNAL UNIT B - PCEB

- Oxford fabric+PVC coating
- One side opening with two fabric ropes fasten

Code	LxWxH(mm)
PCEB700	700x250x550
PCEB810	810x290x560
PCEB840	840x340x640
PCEB860	860x325x840
PCEB945	945x310x610
PCEB970	970x370x750



AC AIR CONDITIONER WASHING BAG CLEANING COVER PCE-C

Code	Dimension
PCEC-700	Circumference 2.4m suitable for 9000-18000BTU A/C UNIT
PCEC-701	Circumference 3.2m suitable for 18000-36000BTU A/C UNIT
PCEC-702	Circumference 2.4m + water tube 2.8m suitable for 9000-18000BTU A/C UNIT
PCEC-703	Circumference 3.2m + water tube 2.8m suitable for 18000-36000BTU A/C UNIT



AIR CONDITIONING WASHING

Code	Description
Q536	include water tube of 2.8m



AIR CONDITIONER DEFLECTOR

Code	Material	HxWxL (mm)
ACD-01	ABS	490x170x40
ACD-02	ABS	440x170x45

